



Integra, INT-2270, INT-2170 Power Quality Digital Metering System Communications Guide

The power to measure Quality with a TOUCH.

Contents

1	INTEGRA INT-2270 - Modbus™ Protocol Implementation	3
1.1	Modbus™ Protocol Overview	3
1.2	Modbus™ Protocol Input Registers	3
1.3	Modbus™ Protocol Holding Registers	5
1.3.1	INTEGRA, INT-2100 MODBUS™ Holding Register Parameters	
	Error! Bookmark not defined.	
2	RS485 General Information	6
2.1	Half Duplex	6
2.2	Connecting the Instruments	7
2.3	A and B terminals	7
2.4	Troubleshooting	8
3	MODBUS™ Protocol General Information	9
3.1	MODBUS™ Protocol Message Format	9
3.2	Serial Transmission Modes	10
3.3	MODBUS™ Protocol Message Timing (RTU Mode)	11
3.4	How Characters are Transmitted Serially	11
3.5	Error Checking Methods	12
3.5.1	Parity Checking	12
3.5.2	CRC Checking	12
3.6	Function Codes	13
3.7	IEEE floating point format	13
3.8	MODBUS™ Protocol Commands supported	14
3.9	Holding Registers	14
3.9.1	Read Holding Registers	14
3.9.2	Write Holding Registers	15
3.10	Exception Response	15
3.11	Exception Codes	16
3.11.1	Table of Exception Codes	16
4	APPENDIX 1 - INTEGRA, INT-2270 / INT-2170 MODBUS™ Input Register Parameters	17
5	APPENDIX 2 - INTEGRA, INT-2270 / INT-2170 MODBUS™ HOLDING Register Parameters	24

1 INTEGRA INT-2270 - Modbus™ Protocol Implementation

1.1 Modbus™ Protocol Overview

This section provides basic information for interfacing the Integra, INT-2000 power quality meter to a Modbus™ Protocol network. If background information or more details of the Integra, INT-2100 implementation is required please refer to section 2 and 3 of this document.

The Integra, INT-2100 offers the option of an RS485 communication facility for direct connection to SCADA or other communications systems using the Modbus™ Protocol RTU slave protocol. The Modbus™ Protocol establishes the format for the master's query by placing into it the device address, a function code defining the requested action, any data to be sent, and an error checking field. The slave's response message is also constructed using Modbus™ Protocol. It contains fields confirming the action taken, any data to be returned, and an error-checking field. If an error occurs in receipt of the message, the Integra, INT-2100 will make no response. If the Integra, INT-2100 is unable to perform the requested action, it will construct an error message and send it as the response.

The electrical interface is 2-wire RS485, via 2 screw terminals. Connection should be made using twisted pair screened cable (Typically 22 gauge Belden 8761 or equivalent). All "A" and "B" connections are daisy chained together. The screens should also be connected to the "Gnd" terminal. To avoid the possibility of loop currents, an Earth connection should be made at only one point on the network.

Line topology may or may not require terminating loads depending on the type and length of cable used. Loop (ring) topology does not require any termination load.

The impedance of the termination load should match the impedance of the cable and be at both ends of the line. The cable should be terminated at each end with a 120 ohm (0.25 Watt min.) resistor.

A total maximum length of 3900 feet (1200 metres) is allowed for the RS485 network. A maximum of 32 electrical nodes can be connected, including the controller.

The address of each Integra, INT-2100 can be set to any value between 1 and 247.

The product also supports the broadcast address (00h); in this case all the devices connected to the bus will be written and none of them will send a response.

The minimum interval between the end of a response and the beginning of the next query (to the same device) is 150ms.

The minimum interval between the end of a response and the beginning of the next query (to a different device): 10ms.

Minimum response time-out (to be set on the master): 500ms.

The supervisory programme must allow this period of time to elapse before assuming that the Integra, INT-2100 power quality meter is not going to respond.

The format for each byte in RTU mode is:

Coding System:	8-bit per byte
Data Format:	4 bytes (2 registers) per parameter. Floating point format (to IEEE 754) Most significant register first.
Error Check Field:	2 byte Cyclical Redundancy Check (CRC)
Framing:	1 start bit 8 data bits, least significant bit sent first 1 bit for even/odd parity (or no parity) 1 stop bit if parity is used; 2 bits if no parity

Data Coding

All data values in the Integra, INT-2100 are transferred as 32 bit IEEE 754 floating point numbers, (input and output) therefore each Integra, INT-2100 digital power quality meters value is transferred using two MODBUS™ Protocol registers. All register read requests and data write requests must specify an even number of registers. Attempts to read/write an odd number of registers prompt the Integra, INT-2100 digital power quality meters to return a MODBUS™ Protocol exception message. However, for compatibility with some SCADA systems, Integra, INT-2100 digital power quality meter will respond to any single input or holding register read with an instrument type specific value

The INTEGRA, INT-2100 can transfer a maximum of 124 values in a single transaction, therefore the maximum number of registers that can be requested is 248.

Data Transmission speed is selectable between 9600, 19200 and 38400 baud.

1.2 Modbus™ Protocol Input Registers

Input registers are used to indicate the present values of the measured and calculated electrical quantities.

Each parameter is held in two consecutive 16 bit registers. The following table details the 3X register address, and the values of the address bytes within the message. A tick (√) in the column indicates that the parameter is valid for the particular wiring system. Any parameter with a cross (X) will return the value Zero. Each parameter is held in the 3X registers. Modbus™ Protocol Function Code 04 is used to access all parameters.

For example, to request:-

Amps 1	Start address	= 0006
	No of registers	= 0002
Amps 2	Start address	= 0008
	No of registers	= 0002

Each request for data must be restricted to 40 parameters or less. Exceeding the 40 parameter limit will cause a Modbus™ Protocol exception code to be returned.

1.3 Modbus™ Protocol Holding Registers

Holding registers are used to store and display instrument configuration settings. All holding registers not listed in the table below should be considered as reserved for manufacturer use and no attempt should be made to modify their values.

The holding register parameters may be viewed or changed using the Modbus™ Protocol. Each parameter is held in two consecutive 4X registers. Modbus™ Protocol Function Code 03 is used to read the parameter and Function Code 16 is used to write. Write to only one parameter per message.

Writing operations MUST be preceded by writing the value 0000 0005h to the Write Enabled registers (40513 and 40514).

This remains enabled once the value is changed or the instrument is switched off.

Writing to registers without the above enable message will generate an exception response 01 "illegal function".

2 RS485 General Information

RS485 or EIA (Electronic Industries Association) RS485 is a balanced line, half-duplex transmission system allowing transmission distances of up to 1.2 km. The following table summarises the RS-485 Standard:

PARAMETER	
Mode of Operation	Differential
Number of Drivers and Receivers	32 Drivers, 32 Receivers
Maximum Cable Length	1200 m
Maximum Data Rate	10 M baud
Maximum Common Mode Voltage	12 V to -7 V
Minimum Driver Output Levels (Loaded)	+/- 1.5 V
Minimum Driver Output Levels (Unloaded)	+/- 6 V
Drive Load	Minimum 60 ohms
Driver Output Short Circuit Current Limit	150 mA to Gnd, 250 mA to 12 V 250 mA to -7 V
Minimum Receiver Input Resistance	12 kohms
Receiver Sensitivity	+/- 200 mV

Further information relating to RS485 may be obtained from either the EIA or the various RS485 device manufacturers, for example Texas Instruments or Maxim Semiconductors. This list is not exhaustive.

2.1 Half Duplex

Half duplex is a system in which one or more transmitters (talkers) can communicate with one or more receivers (listeners) with only one transmitter being active at any one time. For example, a "conversation" is started by asking a question, the person who has asked the question will then listen until he gets an answer or until he decides that the individual who was asked the question is not going to reply.

In a 485 network the "master" will start the "conversation" with a "query" addressed to a specific "slave", the "master" will then listen for the "slave's" response. If the "slave" does not respond within a pre-defined period, (set by control software in the "master"), the "master" will abandon the "conversation".

2.2 Connecting the Instruments

If connecting an RS485 network to a PC use caution if contemplating the use of an RS232 to 485 converter together with a USB to RS485 adapter. Consider either an RS232 to RS485 converter, connected directly to a suitable RS232 jack on the PC, or use a USB to RS485 converter or, for desktop PCs a suitable plug in RS485 card. (*Many 232:485 converters draw power from the RS232 socket. If using a USB to RS232 adapter, the adapter may not have enough power available to run the 232:485 converter.*)

Screened twisted pair cable should be used. For longer cable runs or noisier environments, use of a cable specifically designed for RS485 may be necessary to achieve optimum performance. All "A" terminals should be connected together using one conductor of the twisted pair cable, all "B" terminals should be connected together using the other conductor in the pair. The cable screen should be connected to the "Gnd" terminals.

A Belden 9841 (Single pair) or 9842 (Two pair) or similar cable with a characteristic impedance of 120 ohms is recommended. The cable should be terminated at each end with a 120 ohm, quarter watt (or greater) resistor. Note: Diagram shows wiring topology only. Always follow terminal identification on Integra, INT-2100 digital power quality meter product label.

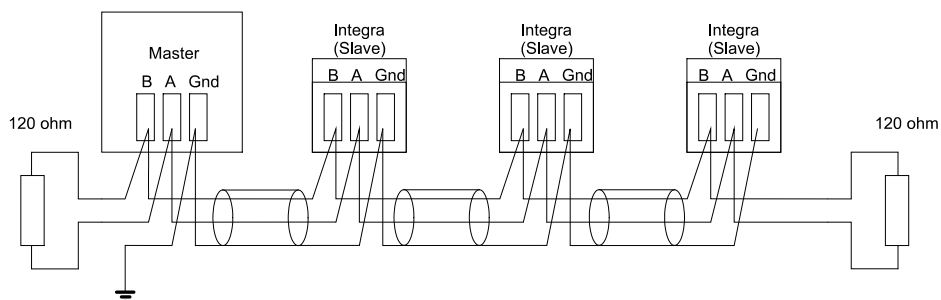

There must be no more than two wires connected to each terminal, this ensures that a "Daisy Chain or "straight line" configuration is used. A "Star" or a network with "Stubs (Tees)" is not recommended as reflections within the cable may result in data corruption.

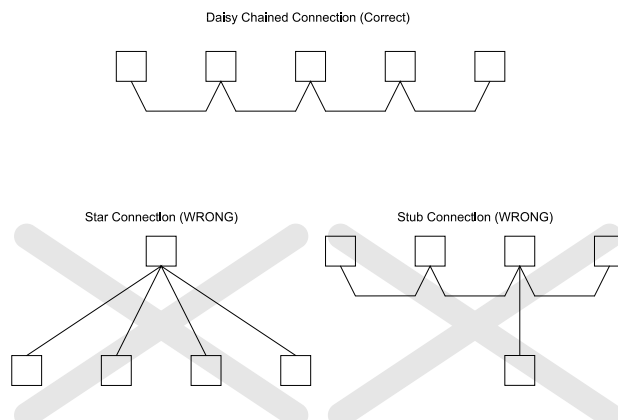

2.3 A and B terminals

The A and B connections to the Integra, INT-2100 digital power quality meter product can be identified by the signals present on them whilst there is activity on the RS485 bus:

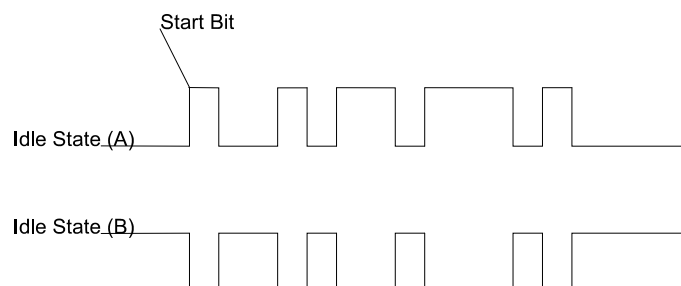

2.4 Troubleshooting

- Start with a simple network, one master and one slave. With Integra, INT-2100 digital power quality meter products this is easily achieved as the network can be left intact whilst individual instruments are disconnected by removing the RS485 connection from the rear of the instrument.
- Check that the network is connected together correctly. That is all of the “A’s” are connected together, and all of the “B’s” are connected together, and also that all of the “Gnd’s” are connected together.
- Confirm that the data “transmitted” onto the RS485 is not echoed back to the PC on the RS232 lines. (This facility is sometimes a link option within the converter). Many PC based packages seem to not perform well when they receive an echo of the message they are transmitting. SpecView and PCView (PC software) with a RS232 to RS485 converter are believed to include this feature.
- Confirm that the Address of the instrument is the same as the “master” is expecting.
- If the “network” operates with one instrument but not more than one check that each instrument has a unique address.
- Each request for data must be restricted to 40 parameters. Violating this requirement will impact the performance of the instrument and may result in a response time in excess of the specification.
- Check that the MODBUS™ Protocol mode (RTU or ASCII) and serial parameters (baud rate, number of data bits, number of stop bits and parity) are the same for all devices on the network.
- Check that the “master” is requesting floating-point variables (pairs of registers placed on floating point boundaries) and is not “splitting” floating point variables.
- Check that the floating-point byte order expected by the “master” is the same as that used by Integra, INT-2100 digital power quality meter products. (PCView and Citect packages can use a number of formats including that supported by Integra, INT-2100 digital power quality meter).
- If possible obtain a second RS232 to RS485 converter and connect it between the RS485 bus and an additional PC equipped with a software package, which can display the data on the bus. Check for the existence of valid requests.

3 MODBUS™ Protocol General Information

Communication on a MODBUS™ Protocol Network is initiated (started) by a “Master” sending a query to a “Slave”. The “Slave”, which is constantly monitoring the network for queries addressed to it, will respond by performing the requested action and sending a response back to the “Master”. Only the “Master” can initiate a query.

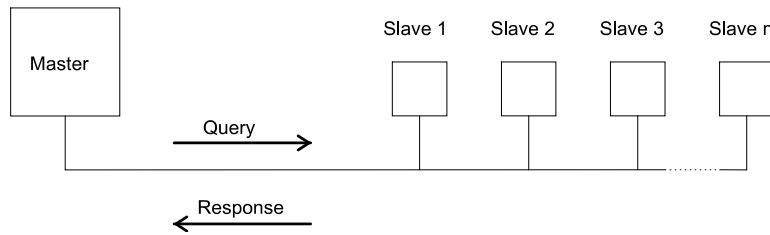

In the MODBUS™ Protocol the master can address individual slaves, or, using a special “Broadcast” address, can initiate a broadcast message to all slaves. The Integra, INT-2100 digital power quality meter does not support the broadcast address.

3.1 MODBUS™ Protocol Message Format

The MODBUS™ Protocol defines the format for the master’s query and the slave’s response.

The query contains the device (or broadcast) address, a function code defining the requested action, any data to be sent, and an error-checking field.

The response contains fields confirming the action taken, any data to be returned, and an error-checking field. If an error occurred in receipt of the message then the message is ignored, if the slave is unable to perform the requested action, then it will construct an error message and send it as its response.

The MODBUS™ Protocol functions used by the Integra, INT-2100 digital power quality meter copy 16 bit register values between master and slaves. However, the data used by the Integra, INT-2100 digital power quality meter is in 32 bit IEEE 754 floating point format. Thus each instrument parameter is conceptually held in two adjacent MODBUS™ Protocol registers.

Query

The following example illustrates a request for a single floating point parameter i.e. two 16-bit Modbus™ Protocol Registers.

First Byte						Last Byte	
Slave Address	Function Code	Start Address (Hi)	Start Address (Lo)	Number of Points (Hi)	Number of Points (Lo)	Error Check (Lo)	Error Check (Hi)

Slave Address: 8-bit value representing the slave being addressed (1 to 247), 0 is reserved for the broadcast address. The Integra, INT-2100 digital power quality meter do not support the broadcast address.

Function Code: 8-bit value telling the addressed slave what action is to be performed. (3, 4, 8 or 16 are valid for Integra, INT-2100 digital power quality meter)

Start Address (Hi): The top (most significant) eight bits of a 16-bit number specifying the start address of the data being requested.

Start Address (Lo): The bottom (least significant) eight bits of a 16-bit number specifying the start address of the data being requested. As registers are used in pairs and start at zero, then this must be an even number.

Number of Points (Hi): The top (most significant) eight bits of a 16-bit number specifying the number of registers being requested.

Number of Points (Lo): The bottom (least significant) eight bits of a 16-bit number specifying the number of registers being requested. As registers are used in pairs, then this must be an even number.

Error Check (Lo): The bottom (least significant) eight bits of a 16-bit number representing the error check value.

Error Check (Hi): The top (most significant) eight bits of a 16-bit number representing the error check value.

Response

The example illustrates the normal response to a request for a single floating point parameter i.e. two 16-bit Modbus™ Protocol Registers.

First Byte							Last Byte	
Slave Address	Function Code	Byte Count	First Register (Hi)	First Register (Lo)	Second Register (Hi)	Second Register (Lo)	Error Check (Lo)	Error Check (Hi)

- Slave Address: 8-bit value representing the address of slave that is responding.
- Function Code: 8-bit value which, when a copy of the function code in the query, indicates that the slave recognised the query and has responded. (See also Exception Response).
- Byte Count: 8-bit value indicating the number of data bytes contained within this response
- First Register (Hi)*: The top (most significant) eight bits of a 16-bit number representing the first register requested in the query.
- First Register (Lo)*: The bottom (least significant) eight bits of a 16-bit number representing the first register requested in the query.
- Second Register (Hi)*: The top (most significant) eight bits of a 16-bit number representing the second register requested in the query.
- Second Register (Lo)*: The bottom (least significant) eight bits of a 16-bit number representing the second register requested in the query.
- Error Check (Lo): The bottom (least significant) eight bits of a 16-bit number representing the error check value.
- Error Check (Hi): The top (most significant) eight bits of a 16-bit number representing the error check value.

* These four bytes together give the value of the floating point parameter requested.

Exception Response

If an error is detected in the content of the query (excluding parity errors and Error Check mismatch), then an error response (called an exception response), will be sent to the master. The exception response is identified by the function code being a copy of the query function code but with the most-significant bit set. The data contained in an exception response is a single byte error code.

First Byte		Last Byte		
Slave Address	Function Code	Error Code	Error Check (Lo)	Error Check (Hi)

- Slave Address: 8-bit value representing the address of slave that is responding.
- Function Code: 8 bit value which is the function code in the query OR'ed with 80 hex, indicating that the slave either does not recognise the query or could not carry out the action requested.
- Error Code: 8-bit value indicating the nature of the exception detected. (See "Table Of Exception Codes" later).
- Error Check (Lo): The bottom (least significant) eight bits of a 16-bit number representing the error check value.
- Error Check (Hi): The top (most significant) eight bits of a 16-bit number representing the error check value.

3.2 Serial Transmission Modes

There are two MODBUS™ Protocol serial transmission modes, ASCII and RTU. Integra, INT-2100 digital power quality meter does not support the ASCII mode.

In RTU (Remote Terminal Unit) mode, each 8-bit byte is used in the full binary range and is not limited to ASCII characters as in ASCII Mode. The greater data density allows better data throughput for the same

baud rate, however each message must be transmitted in a continuous stream. This is very unlikely to be a problem for modern communications equipment.

The format for each byte in RTU mode is:

Coding System:	Full 8-bit binary per byte. In this document, the value of each byte will be shown as two hexadecimal characters each in the range 0-9 or A-F.
Line Protocol:	1 start bit, followed by the 8 data bits. The 8 data bits are sent with least significant bit first.
User Option Of Parity And Stop Bits:	No Parity and 2 Stop Bits Even Parity and 1 Stop Bit. Odd Parity and 1 Stop Bit.
User Option of Baud Rate:	9600 ; 19200 ; 38400

The baud rate, parity and stop bits must be selected to match the master's settings.

3.3 MODBUS™ Protocol Message Timing (RTU Mode)

A MODBUS™ Protocol message has defined beginning and ending points. The receiving devices recognises the start of the message, reads the "Slave Address" to determine if they are being addressed and knowing when the message is completed they can use the Error Check bytes and parity bits to confirm the integrity of the message. If the Error Check or parity fails then the message is discarded.

In RTU mode, messages starts with a silent interval of at least 3.5 character times.

The first byte of a message is then transmitted, the device address.

Master and slave devices monitor the network continuously, including during the 'silent' intervals. When the first byte (the address byte) is received, each device checks it to find out if it is the addressed device. If the device determines that it is the one being addressed it records the whole message and acts accordingly, if it is not being addressed it continues monitoring for the next message.

Following the last transmitted byte, a silent interval of at least 3.5 character times marks the end of the message. A new message can begin after this interval.

The entire message must be transmitted as a continuous stream. If a silent interval of more than 1.5 character times occurs before completion of the message, the receiving device flushes the incomplete message and assumes that the next byte will be the address byte of a new message.

Similarly, if a new message begins earlier than 3.5 character times following a previous message, the receiving device may consider it a continuation of the previous message. This will result in an error, as the value in the final CRC field will not be valid for the combined messages.

3.4 How Characters are Transmitted Serially

When messages are transmitted on standard MODBUS™ Protocol serial networks each byte is sent in this order (left to right):

Transmit Character = Start Bit + Data Byte + Parity Bit + 1 Stop Bit (11 bits total):

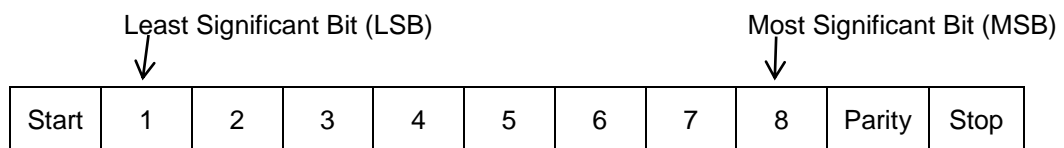

Transmit Character = Start Bit + Data Byte + 2 Stop Bits (11 bits total):

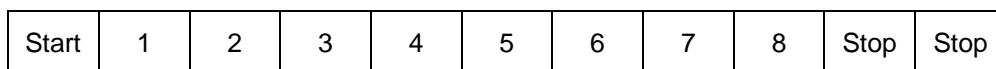

Integra, INT-2100 digital power quality meter additionally support No parity, One stop bit.

Transmit Character = Start Bit + Data Byte + 1 Stop Bit (10 bits total):

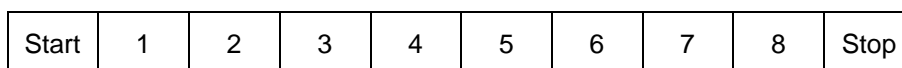

The master is configured by the user to wait for a predetermined timeout interval. The master will wait for this period of time before deciding that the slave is not going to respond and that the transaction should be aborted. Care must be taken when determining the timeout period from both the master and the slaves' specifications. The slave may define the 'response time' as being the period from the receipt of the last bit of the query to the transmission of the first bit of the response. The master may define the 'response time' as period between transmitting the first bit of the query to the receipt of the last bit of the response. It can be seen that message transmission time, which is a function of the baud rate, must be included in the timeout calculation.

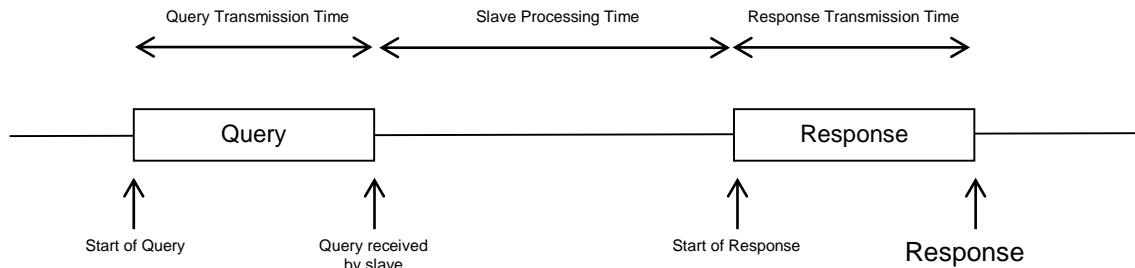

3.5 Error Checking Methods

Standard MODBUS™ Protocol serial networks use two error checking processes, the error check bytes mentioned above check message integrity whilst Parity checking (even or odd) can be applied to each byte in the message.

3.5.1 Parity Checking

If parity checking is enabled – by selecting either Even or Odd Parity - the quantity of “1’s” will be counted in the data portion of each transmit character. The parity bit will then be set to a 0 or 1 to result in an Even or Odd total of “1’s”.

Note that parity checking can only detect an error if an odd number of bits are picked up or dropped in a transmit character during transmission, if for example two 1’s are corrupted to 0’s the parity check will not find the error.

If No Parity checking is specified, no parity bit is transmitted and no parity check can be made. Also, if No Parity checking is specified and one stop bit is selected the transmit character is effectively shortened by one bit.

3.5.2 CRC Checking

The error check bytes of the MODBUS™ Protocol messages contain a Cyclical Redundancy Check (CRC) value that is used to check the content of the entire message. The error check bytes must always be present to comply with the MODBUS™ Protocol, there is no option to disable it.

The error check bytes represent a 16-bit binary value, calculated by the transmitting device. The receiving device must recalculate the CRC during receipt of the message and compare the calculated value to the value received in the error check bytes. If the two values are not equal, the message should be discarded. The error check calculation is started by first pre-loading a 16-bit register to all 1’s (i.e. Hex (FFFF)) each successive 8-bit byte of the message is applied to the current contents of the register. Note: only the eight bits of data in each transmit character are used for generating the CRC, start bits, stop bits and the parity bit, if one is used, are not included in the error check bytes.

During generation of the error check bytes, each 8-bit message byte is exclusive OR’ed with the lower half of the 16 bit register. The register is then shifted eight times in the direction of the least significant bit (LSB), with a zero filled into the most significant bit (MSB) position. After each shift the LSB prior to the shift is extracted and examined. If the LSB was a 1, the register is then exclusive OR’ed with a pre-set, fixed value. If the LSB was a 0, no exclusive OR takes place.

This process is repeated until all eight shifts have been performed. After the last shift, the next 8-bit message byte is exclusive OR’ed with the lower half of the 16 bit register, and the process repeated. The final contents of the register, after all the bytes of the message have been applied, is the error check value.

3.6 Function Codes

The function code part of a MODBUS™ Protocol message defines the action to be taken by the slave. Integra, INT-2100 digital power quality meter supports the following function codes:

Code	MODBUS™ Protocol name	Description
03	Read Holding Registers	Read the contents of read/write location (4X references)
08	Diagnostics	Only sub-function zero is supported. This returns the data element of the query unchanged.
16 (10h)	Pre-set Multiple Registers	Set the contents of read/write location (4X references)

3.7 IEEE floating point format

The MODBUS™ Protocol defines 16 bit “Registers” for the data variables. A 16-bit number would prove too restrictive, for energy parameters for example, as the maximum range of a 16-bit number is 65535. However, there are a number of approaches that have been adopted to overcome this restriction. Integra, INT-2100 digital power quality meter use two consecutive registers to represent a floating-point number, effectively expanding the range to +/- 1x10³⁷.

The values produced by Integra, INT-2100 digital power quality meter can be used directly without any requirement to “scale” the values, for example, the units for the voltage parameters are volts, the units for the power parameters are watts etc.

What is a floating point Number?

A floating-point number is a number with two parts, a mantissa and an exponent and is written in the form 1.234 x 10⁵. The mantissa (1.234 in this example) must have the decimal point moved to the right with the number of places determined by the exponent (5 places in this example) i.e. 1.234x 10⁵ = 123400. If the exponent is negative the decimal point is moved to the left.

What is an IEEE 754 format floating-point number?

An IEEE 754 floating point number is the binary equivalent of the decimal floating-point number shown above. The major difference being that the most significant bit of the mantissa is always arranged to be 1 and is thus not needed in the representation of the number. The process by which the most significant bit is arranged to be 1 is called normalisation, the mantissa is thus referred to as a “normal mantissa”. During normalisation the bits in the mantissa are shifted to the left whilst the exponent is decremented until the most significant bit of the mantissa is one. In the special case where the number is zero both mantissa and exponent are zero.

The bits in an IEEE 754 format have the following significance:

Data Hi Reg, Hi Byte.	Data Hi Reg, Lo Byte.	Data Lo Reg, Hi Byte.	Data Lo Reg, Lo Byte.
EEEE	EMMM	MMMM	MMMM
EEEE	MMMM	MMMM	MMMM

Where:

S represents the sign bit where 1 is negative and 0 is positive

E is the 8-bit exponent with an offset of 127 i.e. an exponent of zero is represented by 127, an exponent of 1 by 128 etc.

M is the 23-bit normal mantissa. The 24th bit is always 1 and, therefore, is not stored.

Using the above format the floating point number 240.5 is represented as 43708000 hex:

Data Hi Reg, Hi Byte	Data Hi Reg, Lo Byte	Data Lo Reg, Hi Byte	Data Lo Reg, Lo Byte
43	70	80	00

The following example demonstrates how to convert IEEE 754 floating-point numbers from their hexadecimal form to decimal form. For this example, we will use the value for 240.5 shown above. Note that the floating-point storage representation is not an intuitive format. To convert this value to decimal, the bits should be separated as specified in the floating-point number storage format table shown above.

For example:

Data Hi Reg, Hi Byte	Data Hi Reg, Lo Byte	Data Lo Reg, Hi Byte	Data Lo Reg, Lo Byte
0100 0011	0111 0000	1000 0000	0000 0000

From this you can determine the following information.

- The sign bit is 0, indicating a positive number.
- The exponent value is 10000110 binary or 134 decimal. Subtracting 127 from 134 leaves 7, which is the actual exponent.
- The mantissa appears as the binary number 111000010000000000000000

There is an implied binary point at the left of the mantissa that is always preceded by a 1. This bit is not stored in the hexadecimal representation of the floating-point number. Adding 1 and the binary point to the beginning of the mantissa gives the following:

1.111000010000000000000000

Now, we adjust the mantissa for the exponent. A negative exponent moves the binary point to the left. A positive exponent moves the binary point to the right. Because the exponent is 7, the mantissa is adjusted as follows:

11110000.1000000000000000

Finally, we have a binary floating-point number. Binary bits that are to the left of the binary point represent the power of two corresponding to their position. For example, 11110000 represents $(1 \times 2^7) + (1 \times 2^6) + (1 \times 2^5) + (1 \times 2^4) + (0 \times 2^3) + (0 \times 2^2) + (0 \times 2^1) + (0 \times 2^0) = 240$.

Binary bits that are to the right of the binary point also represent a power of 2 corresponding to their position. As the digits are to the right of the binary point the powers are negative. For example: .100 represents $(1 \times 2^{-1}) + (0 \times 2^{-2}) + (0 \times 2^{-3}) + \dots$ which equals 0.5.

Adding these two numbers together and making reference to the sign bit produces the number +240.5.

For each floating point value requested two MODBUS™ Protocol registers (four bytes) must be requested. The received order and significance of these four bytes for Integra, INT-2100 digital power quality meter is shown below:

Data Hi Reg, Hi Byte	Data Hi Reg, Lo Byte	Data Lo Reg, Hi Byte	Data Lo Reg, Lo Byte
-------------------------	-------------------------	-------------------------	-------------------------

3.8 MODBUS™ Protocol Commands supported

All Integra, INT-2100 digital power quality meters support the “Read Holding Register” (4X registers) and the “Pre-set Multiple Registers” (write 4X registers) commands of the MODBUS™ Protocol RTU protocol. All values stored and returned are in floating point format to IEEE 754 with the most significant register first.

3.9 Holding Registers

3.9.1 Read Holding Registers

MODBUS™ Protocol code 03 reads the contents of the 4X registers.

Example

The following query will request the V L1-N:

Field Name	Example (Hex)
Slave Address	01
Function	03
Starting Address High	00
Starting Address Low	00
Number of Points High	00
Number of Points Low	02
Error Check Low	C4
Error Check High	0B

Note: Data must be requested in register pairs i.e. the “Starting Address” and the “Number of Points” must be even numbers to request a floating point variable. If the “Starting Address” or the “Number of points” is odd then the query will fall in the middle of a floating point variable the product will return an error message.

The following response returns the contents of V L1-N, But see also “Exception Response” later.

Field Name	Example (Hex)
Slave Address	01
Function	03
Byte Count	04
Data, High Reg, High Byte	00
Data, High Reg, Low Byte	00
Data, Low Reg, High Byte	00
Data, Low Reg, Low Byte	E6
Error Check Low	F7
Error Check High	CF

3.9.2 Write Holding Registers

MODBUS™ Protocol code 16 (160h hex) writes the contents of the 4X registers.

Example

The following query will set the Write Enable register to 0000 00A5 (hex), which enables writing to other registers. Writing remains enabled until this value is changed or the power supply is removed.

Field Name	Example (Hex)
Slave Address	01
Function	10
Starting Address High	02
Starting Address Low	00
Number of Registers High	00
Number of Registers Low	02
Byte Count	04
Data, High Reg, High Byte	00
Data, High Reg, Low Byte	00
Data, Low Reg, High Byte	00
Data, Low Reg, Low Byte	A5
Error Check Low	67
Error Check High	D5

Note: Data must be written in register pairs i.e. the “Starting Address” and the “Number of Points” must be even numbers to write a floating point variable. If the “Starting Address” or the “Number of points” is odd then the query will fall in the middle of a floating point variable the product will return an error message. In general only one floating point value can be written per query

The following response indicates that the write has been successful. But see also “Exception Response” later.

Field Name	Example (Hex)
Slave Address	01
Function	10
Starting Address High	00
Starting Address Low	02
Number of Registers High	00
Number of Registers Low	02
Error Check Low	E0
Error Check High	08

3.10 Exception Response

If the slave in the “Write Holding Register” example above, did not support that function then it would have replied with an Exception Response as shown below. The exception function code is the original function code from the query with the MSB set i.e. it has had 80 hex logically ORed with it. The exception code

indicates the reason for the exception. The slave will not respond at all if there is an error with the parity or CRC of the query. However, if the slave can not process the query then it will respond with an exception. In this case a code 01, the requested function is not support by this slave.

Field Name	Example (Hex)
Slave Address	01
Function	10 OR 80 = 90
Exception Code	01
Error Check Low	8D
Error Check High	C0

3.11 Exception Codes

3.11.1 Table of Exception Codes

Integra, INT-2100 digital power quality meters support the following exception codes:

Exception Code	MODBUS™ Protocol name	Description
01	Illegal Function	The function code is not supported by the product OR Writing not enabled
02	Illegal Data Address	Attempt to access an invalid address
03	Illegal Data Value	Attempt to set a floating point variable to an invalid value

While TE has made every reasonable effort to ensure the accuracy of the information in this catalogue, TE does not guarantee that it is error-free, nor does TE make any other representation, warranty or guarantee that the information is accurate, correct, reliable or current. TE reserves the right to make any adjustments to the information contained herein at any time without notice. TE expressly disclaims all implied warranties regarding the information contained herein, including, but not limited to, any implied warranties of merchantability or fitness for a particular purpose. The dimensions in this catalogue are for reference purposes only and are subject to change without notice. Specifications are subject to change without notice. Consult TE for the latest dimensions and design specifications. TE connectivity (logo), TE (logo) and TE Connectivity are trademarks of the TE Connectivity Ltd. family of companies. Crompton is a trademark of Crompton Parkinson and is used by TE Connectivity under a licence. Other logos, product and company names mentioned herein may be trademarks of their respective owners

TE Energy – innovative and economical solutions for the electrical power industry: cable accessories, connectors & fittings, insulators & insulation, surge arresters, switching equipment, street lighting, power measurement and control.

Tyco Electronics UK Ltd
 TE Energy
 Freebournes Road
 Witham, Essex CM8 3AH
 Phone: +44 (0)870 870 7500
 Fax: +44 (0)870 240 5287

Email: Crompton.info@te.com
www.crompton-instruments.com



4 APPENDIX 1 - INTEGRA, INT-2270 / INT-2170 MODBUS™ Input Register Parameters

Parameter Number	Address	Register	Parameter Units	Parameter Name	Parameter Description	Modbus™ Start Address (Hex)		3P4W	3P3W	1P3W	1P2W	INT-2170	INT-2270	INT-1630	Alarm	Custom Log
						Hi Byte	Lo Byte									
1	30001	30000	Volts	V1	Phase 1 line to neutral voltage.	00	00	Yes	Yes	Yes	Yes	Yes	Yes	Yes	Yes	Yes
2	30003	30002	Volts	V2	Phase 2 line to neutral voltage.	00	02	Yes	Yes	No	No	Yes	Yes	Yes	Yes	Yes
3	30005	30004	Volts	V3	Phase 3 line to neutral voltage.	00	04	Yes	Yes	No	No	Yes	Yes	Yes	Yes	Yes
4	30007	30006	Amps	A1	Line 1 current.	00	06	Yes	Yes	Yes	Yes	Yes	Yes	Yes	Yes	Yes
5	30009	30008	Amps	A2	Line 2 current.	00	08	Yes	Yes	No	No	Yes	Yes	Yes	Yes	Yes
6	30011	30010	Amps	A3	Line 3 current.	00	0A	Yes	Yes	No	No	Yes	Yes	Yes	Yes	Yes
7	30013	30012	Watts	P1	Phase 1 power.	00	0C	Yes	No	Yes	Yes	Yes	Yes	Yes	Yes	Yes
8	30015	30014	Watts	P2	Phase 2 power.	00	0E	Yes	No	No	No	Yes	Yes	Yes	Yes	Yes
9	30017	30016	Watts	P3	Phase 3 power.	00	10	Yes	No	No	No	Yes	Yes	Yes	Yes	Yes
10	30019	30018	VA	VA1	Phase 1 VA.	00	12	Yes	No	Yes	Yes	Yes	Yes	Yes	Yes	Yes
11	30021	30020	VA	VA2	Phase 2 VA.	00	14	Yes	No	No	No	Yes	Yes	Yes	Yes	Yes
12	30023	30022	VA	VA3	Phase 3 VA.	00	16	Yes	No	No	No	Yes	Yes	Yes	Yes	Yes
13	30025	30024	VAr	VAr1	Phase 1 VAr.	00	18	Yes	No	Yes	Yes	Yes	Yes	Yes	Yes	Yes
14	30027	30026	VAr	VAr2	Phase 2 VAr.	00	1A	Yes	No	No	No	Yes	Yes	Yes	Yes	Yes
15	30029	30028	VAr	VAr3	Phase 3 VAr.	00	1C	Yes	No	No	No	Yes	Yes	Yes	Yes	Yes
16	30031	30030	None	PF1	Phase 1 power factor.	00	1E	Yes	No	Yes	Yes	Yes	Yes	Yes	Yes	Yes
17	30033	30032	None	PF2	Phase 2 power factor.	00	20	Yes	No	No	No	Yes	Yes	Yes	Yes	Yes
18	30035	30034	None	PF3	Phase 3 power factor.	00	22	Yes	No	No	No	Yes	Yes	Yes	Yes	Yes
19	30037	30036	Degrees	PA1	Phase 1 phase angle.	00	24	Yes	No	Yes	Yes	Yes	Yes	Yes	Yes	Yes
20	30039	30038	Degrees	PA2	Phase 2 phase angle.	00	26	Yes	No	No	No	Yes	Yes	Yes	Yes	Yes
21	30041	30040	Degrees	PA3	Phase 3 phase angle.	00	28	Yes	No	No	No	Yes	Yes	Yes	Yes	Yes
22	30043	30042	Volts	VLNAvg	Average line to neutral voltage.	00	2A	Yes	Yes	Yes	Yes	Yes	Yes	Yes	Yes	Yes
23	30045	30044	--	--	--	--	--	--	--	--	--	--	--	--	No	No
24	30047	30046	Amps	AAvg	Average line current.	00	2E	Yes	Yes	Yes	Yes	Yes	Yes	Yes	Yes	Yes
25	30049	30048	Amps	ASum	Sum of line currents.	00	30	Yes	Yes	Yes	Yes	Yes	Yes	Yes	Yes	Yes
26	30051	30050	--	--	--	--	--	--	--	--	--	--	--	--	No	No
27	30053	30052	Watts	PSum	Sum of phase powers.	00	34	Yes	Yes	Yes	Yes	Yes	Yes	Yes	Yes	Yes
28	30055	30054	--	--	--	--	--	--	--	--	--	--	--	--	No	No
29	30057	30056	VA	VASum	Sum of phase VAs.	00	38	Yes	Yes	Yes	Yes	Yes	Yes	Yes	Yes	Yes
30	30059	30058	--	--	--	--	--	--	--	--	--	--	--	--	No	No
31	30061	30060	VAr	VArSum	Sum of phase VAr.	00	3C	Yes	Yes	Yes	Yes	Yes	Yes	Yes	Yes	Yes
32	30063	30062	None	PFTot	Total system power factor.	00	3E	Yes	Yes	Yes	Yes	Yes	Yes	Yes	Yes	Yes
33	30065	30064	--	--	--	--	--	--	--	--	--	--	--	--	No	No
34	30067	30066	Degrees	PATot	Total system phase angle.	00	42	Yes	Yes	Yes	Yes	Yes	Yes	Yes	Yes	Yes
35	30069	30068	--	--	--	--	--	--	--	--	--	--	--	--	No	No
36	30071	30070	Hz	Frq	System frequency.	00	46	Yes	Yes	Yes	Yes	Yes	Yes	Yes	Yes	Yes
37	30073	30072	Watt Hours	ImpWh	Import Watt hours.	00	48	Yes	Yes	Yes	Yes	Yes	Yes	Yes	Yes	Yes
38	30075	30074	Watt Hours	ExpWh	Export Watt hours.	00	4A	Yes	Yes	Yes	Yes	Yes	Yes	Yes	Yes	Yes
39	30077	30076	VAr Hours	ImpVArh	Import VAr hours.	00	4C	Yes	Yes	Yes	Yes	Yes	Yes	Yes	Yes	Yes
40	30079	30078	VAr Hours	ExpVArh	Export VAr hours.	00	4E	Yes	Yes	Yes	Yes	Yes	Yes	Yes	Yes	Yes
41	30081	30080	VA Hours	VAh	VA hours.	00	50	Yes	Yes	Yes	Yes	Yes	Yes	Yes	Yes	Yes
42	30083	30082	A Hours	ASumh	Current sum hours.	00	52	--	--	--	--	Yes	Yes	--	Yes	Yes
43	30085	30084	Watts	PSumDmd	Import power sum demand.	00	54	Yes	Yes	Yes	Yes	Yes	Yes	Yes	Yes	Yes
44	30087	30086	Watts	PSumDmdMax	Maximum import power sum demand.	00	56	Yes	Yes	Yes	Yes	Yes	Yes	Yes	Yes	Yes
45	30089	30088	Pulse Count	PCnt1	Input pulse count 1	00	58	Yes	Yes	Yes	Yes	Yes	Yes	--	Yes	Yes
	29999	29998	--	--	--	--	--	--	--	--	--	--	--	--	--	--
46	30091	30090	Pulse Count	PCnt2	Input pulse count 2	00	5A	Yes	Yes	Yes	Yes	Yes	Yes	--	Yes	Yes
	29999	29998	--	--	--	--	--	--	--	--	--	--	--	--	No	No
47	30093	30092	--	--	--	--	--	--	--	--	--	--	--	--	No	No
48	30095	30094	--	--	--	--	--	--	--	--	--	--	--	--	No	No
49	30097	30096	--	--	--	--	--	--	--	--	--	--	--	--	No	No
50	30099	30098	--	--	--	--	--	--	--	--	--	--	--	--	No	No
51	30101	30100	VA	VASumDmd	VA sum demand.	00	64	Yes	Yes	Yes	Yes	Yes	Yes	Yes	Yes	Yes
52	30103	30102	VA	VASumDmdMax	Maximum VA sum demand.	00	66	Yes	Yes	Yes	Yes	Yes	Yes	Yes	Yes	Yes
53	30105	30104	Amps	ASumDmd	Current sum demand.	00	68	Yes	Yes	Yes	Yes	Yes	Yes	Yes	Yes	Yes
54	30107	30106	Amps	ASumDmdMax	Maximum current sum demand.	00	6A	Yes	Yes	Yes	Yes	Yes	Yes	Yes	Yes	Yes
55	30109	30108	Volts	V1Max	Maximum phase 1 line to neutral voltage.	00	6C	Yes	Yes	Yes	Yes	Yes	Yes	--	Yes	Yes
56	30111	30110	Volts	V1Min	Minimum phase 1 line to neutral voltage.	00	6E	Yes	Yes	Yes	Yes	Yes	Yes	--	Yes	Yes
57	30113	30112	Volts	V2Max	Maximum phase 2 line to neutral voltage.	00	70	Yes	Yes	No	No	Yes	Yes	--	Yes	Yes
58	30115	30114	Volts	V2Min	Minimum phase 2 line to neutral voltage.	00	72	Yes	Yes	No	No	Yes	Yes	--	Yes	Yes
59	30117	30116	Volts	V3Max	Maximum phase 3 line to neutral voltage.	00	74	Yes	Yes	No	No	Yes	Yes	--	Yes	Yes
60	30119	30118	Volts	V3Min	Minimum phase 3 line to neutral voltage.	00	76	Yes	Yes	No	No	Yes	Yes	--	Yes	Yes

Parameter Number	Address	Register	Parameter Units	Parameter Name	Parameter Description	Modbus™ Start Address (Hex)		3P4W	3P3W	1P3W	1P2W	INT-2170	INT-2270	INT-1630	Alarm	Custom Log
						Hi Byte	Lo Byte									
61	30121	30120	Amps	A1Max	Maximum line 1 current.	00	78	Yes	Yes	Yes	Yes	Yes	Yes	--	Yes	Yes
62	30123	30122	Amps	A1Min	Minimum line 1 current.	00	7A	Yes	Yes	Yes	Yes	Yes	Yes	--	Yes	Yes
63	30125	30124	Amps	A2Max	Maximum line 2 current.	00	7C	Yes	Yes	Yes	No	Yes	Yes	--	Yes	Yes
64	30127	30126	Amps	A2Min	Minimum line 2 current.	00	7E	Yes	Yes	Yes	No	Yes	Yes	--	Yes	Yes
65	30129	30128	Amps	A3Max	Maximum line 3 current.	00	80	Yes	Yes	No	No	Yes	Yes	--	Yes	Yes
66	30131	30130	Amps	A3Min	Minimum line 3 current.	00	82	Yes	Yes	No	No	Yes	Yes	--	Yes	Yes
67	30133	30132	Volts	VLNAvgMax	Maximum average line to neutral voltage.	00	84	Yes	Yes	Yes	Yes	Yes	Yes	--	Yes	Yes
68	30135	30134	Volts	VLNAvgMin	Minimum average line to neutral voltage.	00	86	Yes	Yes	Yes	Yes	Yes	Yes	--	Yes	Yes
69	30137	30136	--	--	--	--	--	--	--	--	--	--	--	--	No	No
70	30139	30138	--	--	--	--	--	--	--	--	--	--	--	--	No	No
71	30141	30140	Amps	AAvgMax	Maximum average line current.	00	8C	Yes	Yes	Yes	Yes	Yes	Yes	--	Yes	Yes
72	30143	30142	Amps	AAvgMin	Minimum average line current.	00	8E	Yes	Yes	Yes	Yes	Yes	Yes	--	Yes	Yes
73	30145	30144	Amps	ASumMax	Maximum sum of line currents.	00	90	Yes	Yes	Yes	Yes	Yes	Yes	--	Yes	Yes
74	30147	30146	Amps	ASumMin	Minimum sum of line currents.	00	92	Yes	Yes	Yes	Yes	Yes	Yes	--	Yes	Yes
75	30149	30148	Watts	P1Max	Maximum phase 1 power.	00	94	Yes	Yes	Yes	Yes	Yes	Yes	--	Yes	Yes
76	30151	30150	Watts	P1Min	Minimum phase 1 power.	00	96	Yes	Yes	Yes	Yes	Yes	Yes	--	Yes	Yes
77	30153	30152	Watts	P2Max	Maximum phase 2 power.	00	98	Yes	Yes	Yes	No	Yes	Yes	--	Yes	Yes
78	30155	30154	Watts	P2Min	Minimum phase 2 power.	00	9A	Yes	Yes	Yes	No	Yes	Yes	--	Yes	Yes
79	30157	30156	Watts	P3Max	Maximum phase 3 power.	00	9C	Yes	Yes	No	No	Yes	Yes	--	Yes	Yes
80	30159	30158	Watts	P3Min	Minimum phase 3 power.	00	9E	Yes	Yes	No	No	Yes	Yes	--	Yes	Yes
81	30161	30160	Watts	PSumMax	Maximum sum of phase powers.	00	A0	Yes	Yes	Yes	Yes	Yes	Yes	--	Yes	Yes
82	30163	30162	Watts	PSumMin	Minimum sum of phase powers.	00	A2	Yes	Yes	Yes	Yes	Yes	Yes	--	Yes	Yes
83	30165	30164	VAr	VAr1Max	Maximum phase 1 VAr.	00	A4	Yes	Yes	Yes	Yes	Yes	Yes	--	Yes	Yes
84	30167	30166	VAr	VAr1Min	Minimum phase 1 VAr.	00	A6	Yes	Yes	Yes	Yes	Yes	Yes	--	Yes	Yes
85	30169	30168	VAr	VAr2Max	Maximum phase 2 VAr.	00	A8	Yes	Yes	Yes	No	Yes	Yes	--	Yes	Yes
86	30171	30170	VAr	VAr2Min	Minimum phase 2 VAr.	00	AA	Yes	Yes	Yes	No	Yes	Yes	--	Yes	Yes
87	30173	30172	VAr	VAr3Max	Maximum phase 3 VAr.	00	AC	Yes	Yes	No	No	Yes	Yes	--	Yes	Yes
88	30175	30174	VAr	VAr3Min	Minimum phase 3 VAr.	00	AE	Yes	Yes	No	No	Yes	Yes	--	Yes	Yes
89	30177	30176	VAr	VArSumMax	Maximum sum of phase VAr.	00	B0	Yes	Yes	Yes	Yes	Yes	Yes	--	Yes	Yes
90	30179	30178	VAr	VArSumMin	Minimum sum of phase VAr.	00	B2	Yes	Yes	Yes	Yes	Yes	Yes	--	Yes	Yes
91	30181	30180	VA	VA1Max	Maximum phase 1 VAs.	00	B4	Yes	Yes	Yes	Yes	Yes	Yes	--	Yes	Yes
92	30183	30182	VA	VA1Min	Minimum phase 1 VAs.	00	B6	Yes	Yes	Yes	Yes	Yes	Yes	--	Yes	Yes
93	30185	30184	VA	VA2Max	Maximum phase 2 VAs.	00	B8	Yes	Yes	Yes	No	Yes	Yes	--	Yes	Yes
94	30187	30186	VA	VA2Min	Minimum phase 2 VAs.	00	BA	Yes	Yes	Yes	No	Yes	Yes	--	Yes	Yes
95	30189	30188	VA	VA3Max	Maximum phase 3 VAs.	00	BC	Yes	Yes	No	No	Yes	Yes	--	Yes	Yes
96	30191	30190	VA	VA3Min	Minimum phase 3 VAs.	00	BE	Yes	Yes	No	No	Yes	Yes	--	Yes	Yes
97	30193	30192	VA	VASumMax	Maximum sum of phase VAs.	00	C0	Yes	Yes	Yes	Yes	Yes	Yes	--	Yes	Yes
98	30195	30194	VA	VASumMin	Minimum sum of phase VAs.	00	C2	Yes	Yes	Yes	Yes	Yes	Yes	--	Yes	Yes
99	30197	30196	Hz	FrqMax	Maximum system voltage frequency.	00	C4	Yes	Yes	Yes	Yes	Yes	Yes	--	Yes	Yes
100	30199	30198	Hz	FrqMin	Minimum system voltage frequency.	00	C6	Yes	Yes	Yes	Yes	Yes	Yes	--	Yes	Yes
101	30201	30200	Volts	V12	Voltage line 1 to line 2.	00	C8	Yes	Yes	Yes	Yes	Yes	Yes	Yes	Yes	Yes
102	30203	30202	Volts	V23	Voltage line 2 to line 3.	00	CA	Yes	Yes	Yes	No	Yes	Yes	Yes	Yes	Yes
103	30205	30204	Volts	V31	Voltage line 3 to line 1.	00	CC	Yes	Yes	No	No	Yes	Yes	Yes	Yes	Yes
104	30207	30206	Volts	VLLAvg	Average line to line voltage.	00	CE	Yes	Yes	Yes	Yes	Yes	Yes	Yes	Yes	Yes
105	30209	30208	Volts	V12Max	Maximum line 1 to line 2 voltage.	00	D0	Yes	Yes	Yes	Yes	Yes	Yes	--	Yes	Yes
106	30211	30210	Volts	V12Min	Minimum line 1 to line 2 voltage.	00	D2	Yes	Yes	Yes	Yes	Yes	Yes	--	Yes	Yes
107	30213	30212	Volts	V23Max	Maximum line 2 to line 3 voltage.	00	D4	Yes	Yes	Yes	No	Yes	Yes	--	Yes	Yes
108	30215	30214	Volts	V23Min	Minimum line 2 to line 3 voltage.	00	D6	Yes	Yes	Yes	No	Yes	Yes	--	Yes	Yes
109	30217	30216	Volts	V31Max	Maximum line 3 to line 1 voltage.	00	D8	Yes	Yes	No	No	Yes	Yes	--	Yes	Yes
110	30219	30218	Volts	V31Min	Minimum line 3 to line 1 voltage.	00	DA	Yes	Yes	No	No	Yes	Yes	--	Yes	Yes
111	30221	30220	Volts	VLLAvgMax	Maximum average line to line voltage.	00	DC	Yes	Yes	Yes	Yes	Yes	Yes	Yes	Yes	Yes
112	30223	30222	Volts	VLLAvgMin	Minimum average line to line voltage.	00	DE	Yes	Yes	Yes	Yes	Yes	Yes	--	Yes	Yes
113	30225	30224	Amps	ANeu	Neutral current.	00	00	Yes	Yes	Yes	Yes	Yes	Yes	Yes	Yes	Yes
114	30227	30226	Amps	ANeuMax	Maximum neutral current.	00	00	Yes	Yes	Yes	Yes	Yes	Yes	--	Yes	Yes
115	30229	30228	Amps	ANeuMin	Minimum neutral current.	00	00	Yes	Yes	Yes	Yes	Yes	Yes	--	Yes	Yes
116	30231	30230	Amps	ANDmd	Neutral current demand	00	00	Yes	Yes	Yes	Yes	Yes	Yes	--	Yes	Yes
117	30233	30232	Amps	ANDmdMax	Maximum neutral current demand	00	00	Yes	Yes	Yes	Yes	Yes	Yes	--	Yes	Yes
118	30235	30234	%	V1THD	Phase 1 line to neutral voltage THD. *	00	EA	Yes	Yes	Yes	Yes	Yes	Yes	Yes	Yes	Yes
119	30237	30236	%	V2THD	Phase 2 line to neutral voltage THD. *	00	EC	Yes	Yes	Yes	No	Yes	Yes	Yes	Yes	Yes
120	30239	30238	%	V3THD	Phase 3 line to neutral voltage THD. *	00	EE	Yes	Yes	No	No	Yes	Yes	Yes	Yes	Yes
121	30241	30240	%	A1THD	Line 1 current THD.	00	F0	Yes	Yes	Yes	Yes	Yes	Yes	Yes	Yes	Yes
122	30243	30242	%	A2THD	Line 2 current THD.	00	F2	Yes	Yes	Yes	No	Yes	Yes	Yes	Yes	Yes

Parameter Number	Address	Register	Parameter Units	Parameter Name	Parameter Description	Modbus™ Start Address (Hex)		3P4W	3P3W	1P3W	1P2W	INT-2170	INT-2270	INT-1630	Alarm	Custom Log
						Hi Byte	Lo Byte									
123	30245	30244	%	A3THD	Line 3 current THD.	00	F4	Yes	Yes	No	No	Yes	Yes	Yes	Yes	Yes
124	30247	30246	--	--	--	--	--	--	--	--	--	--	--	--	No	No
125	30249	30248	%	VTHDAvg	Average line to neutral voltage THD. *	00	F8	Yes	Yes	Yes	Yes	Yes	Yes	Yes	Yes	Yes
126	30251	30250	%	ATHDAvg	Average line current THD.	00	FA	Yes	Yes	Yes	Yes	Yes	Yes	Yes	Yes	Yes
127	30253	30252	centi hours	HRun	Hours run at over minimum load.	00	FC	Yes	Yes	Yes	Yes	Yes	Yes	Yes	Yes	Yes
128	30255	30254	None	PFTot	Total system power factor, times minus one.	00	FE	Yes	Yes	Yes	Yes	Yes	Yes	Yes	Yes	Yes
129	30257	30256	--	--	--	--	--	--	--	--	--	--	--	--	No	No
130	30259	30258	Amps	A1Dmd	Line 1 current demand.	01	02	Yes	Yes	Yes	Yes	Yes	Yes	Yes	Yes	Yes
131	30261	30260	Amps	A2Dmd	Line 2 current demand.	01	04	Yes	Yes	Yes	No	Yes	Yes	Yes	Yes	Yes
132	30263	30262	Amps	A3Dmd	Line 3 current demand.	01	06	Yes	Yes	No	No	Yes	Yes	Yes	Yes	Yes
133	30265	30264	Amps	A1DmdMax	Maximum line 1 current demand.	01	08	Yes	Yes	Yes	Yes	Yes	Yes	Yes	Yes	Yes
134	30267	30266	Amps	A2DmdMax	Maximum line 2 current demand.	01	0A	Yes	Yes	Yes	No	Yes	Yes	Yes	Yes	Yes
135	30269	30268	Amps	A3DmdMax	Maximum line 3 current demand.	01	0C	Yes	Yes	No	No	Yes	Yes	Yes	Yes	Yes
136	30271	30270	None	PRot	Phase rotation sequence.	01	0E	Yes	Yes	Yes	Yes	Yes	Yes	--	Yes	Yes
137	30273	30272	%	VLNBal	Line to neutral voltage out of balance.	01	10	Yes	Yes	Yes	Yes	Yes	Yes	--	Yes	Yes
138	30275	30274	%	VLLBal	Line to line voltage out of balance.	01	12	Yes	Yes	Yes	Yes	Yes	Yes	--	Yes	Yes
139	30277	30276	%	ABal	Line current out of balance.	01	14	Yes	Yes	Yes	Yes	Yes	Yes	--	Yes	Yes
140	30279	30278	%	VLNBalMax	Maximum line to neutral voltage out of balance.	01	16	Yes	Yes	Yes	Yes	Yes	Yes	--	Yes	Yes
141	30281	30280	%	VLNBalMin	Minimum line to neutral voltage out of balance.	01	18	Yes	Yes	Yes	Yes	Yes	Yes	--	Yes	Yes
142	30283	30282	%	VLLBalMax	Maximum line to line voltage out of balance.	01	1A	Yes	Yes	Yes	Yes	Yes	Yes	--	Yes	Yes
143	30285	30284	%	VLLBalMin	Minimum line to line voltage out of balance.	01	1C	Yes	Yes	Yes	Yes	Yes	Yes	--	Yes	Yes
144	30287	30286	%	ABalMax	Maximum line current out of balance.	01	1E	Yes	Yes	Yes	Yes	Yes	Yes	--	Yes	Yes
145	30289	30288	%	ABalMin	Minimum line current out of balance.	01	20	Yes	Yes	Yes	Yes	Yes	Yes	--	Yes	Yes
146	30291	30290	None	PF1Max	Maximum phase 1 power factor.	01	22	Yes	Yes	Yes	Yes	Yes	Yes	--	Yes	Yes
147	30293	30292	None	PF1Min	Minimum phase 1 power factor.	01	24	Yes	Yes	Yes	Yes	Yes	Yes	--	Yes	Yes
148	30295	30294	None	PF2Max	Maximum phase 2 power factor.	01	26	Yes	Yes	Yes	No	Yes	Yes	--	Yes	Yes
149	30297	30296	None	PF2Min	Minimum phase 2 power factor.	01	28	Yes	Yes	Yes	No	Yes	Yes	--	Yes	Yes
150	30299	30298	None	PF3Max	Maximum phase 3 power factor.	01	2A	Yes	Yes	No	No	Yes	Yes	--	Yes	Yes
151	30301	30300	None	PF3Min	Minimum phase 3 power factor.	01	2C	Yes	Yes	No	No	Yes	Yes	--	Yes	Yes
152	30303	30302	None	PFTotMax	Maximum total system power factor.	01	2E	Yes	Yes	Yes	Yes	Yes	Yes	--	Yes	Yes
153	30305	30304	None	PFTotMin	Minimum total system power factor.	01	30	Yes	Yes	Yes	Yes	Yes	Yes	--	Yes	Yes
154	30307	30306	Degrees	PATotMax	Maximum total system phase angle.	01	32	Yes	Yes	Yes	Yes	Yes	Yes	--	Yes	Yes
155	30309	30308	Degrees	PATotMin	Minimum total system phase angle.	01	34	Yes	Yes	Yes	Yes	Yes	Yes	--	Yes	Yes
156	30311	30310	%	V1THDMax	Maximum phase 1 line to neutral voltage THD. *	01	36	Yes	Yes	Yes	Yes	Yes	Yes	--	Yes	Yes
157	30313	30312	%	V1THDMin	Minimum phase 1 line to neutral voltage THD. *	01	38	Yes	Yes	Yes	Yes	Yes	Yes	--	Yes	Yes
158	30315	30314	%	V2THDMax	Maximum phase 2 line to neutral voltage THD. *	01	3A	Yes	Yes	Yes	No	Yes	Yes	--	Yes	Yes
159	30317	30316	%	V2THDMin	Minimum phase 2 line to neutral voltage THD. *	01	3C	Yes	Yes	Yes	No	Yes	Yes	--	Yes	Yes
160	30319	30318	%	V3THDMax	Maximum phase 3 line to neutral voltage THD. *	01	3E	Yes	Yes	No	No	Yes	Yes	--	Yes	Yes
161	30321	30320	%	V3THDMin	Minimum phase 3 line to neutral voltage THD. *	01	40	Yes	Yes	No	No	Yes	Yes	--	Yes	Yes
162	30323	30322	%	A1THDMax	Maximum line 1 current THD.	01	42	Yes	Yes	Yes	Yes	Yes	Yes	--	Yes	Yes
163	30325	30324	%	A1THDMin	Minimum line 1 current THD.	01	44	Yes	Yes	Yes	Yes	Yes	Yes	--	Yes	Yes
164	30327	30326	%	A2THDMax	Maximum line 2 current THD.	01	46	Yes	Yes	Yes	No	Yes	Yes	--	Yes	Yes
165	30329	30328	%	A2THDMin	Minimum line 2 current THD.	01	48	Yes	Yes	Yes	No	Yes	Yes	--	Yes	Yes
166	30331	30330	%	A3THDMax	Maximum line 3 current THD.	01	4A	Yes	Yes	No	No	Yes	Yes	--	Yes	Yes
167	30333	30332	%	A3THDMin	Minimum line 3 current THD.	01	4C	Yes	Yes	No	No	Yes	Yes	--	Yes	Yes
168	30335	30334	Watts	P1Dmd	Import phase 1 power demand	01	4E	Yes	Yes	Yes	Yes	Yes	Yes	--	Yes	Yes
169	30337	30336	Watts	P2Dmd	Import phase 2 power demand	01	50	Yes	Yes	Yes	No	Yes	Yes	--	Yes	Yes
170	30339	30338	Watts	P3Dmd	Import phase 3 power demand	01	52	Yes	Yes	No	No	Yes	Yes	--	Yes	Yes
171	30341	30340	Watts	P1DmdMax	Import phase 1 power demand maximum	01	54	Yes	Yes	Yes	Yes	Yes	Yes	--	Yes	Yes
172	30343	30342	Watts	P2DmdMax	Import phase 2 power demand maximum	01	56	Yes	Yes	Yes	No	Yes	Yes	--	Yes	Yes
173	30345	30344	Watts	P3DmdMax	Import phase 3 power demand maximum	01	58	Yes	Yes	No	No	Yes	Yes	--	Yes	Yes
174	30347	30346	VA	VA1Dmd	Phase 1 VA demand	01	5A	Yes	Yes	Yes	Yes	Yes	Yes	--	Yes	Yes
175	30349	30348	VA	VA2Dmd	Phase 2 VA demand	01	5C	Yes	Yes	Yes	No	Yes	Yes	--	Yes	Yes
176	30351	30350	VA	VA3Dmd	Phase 3 VA demand	01	5E	Yes	Yes	No	No	Yes	Yes	--	Yes	Yes
177	30353	30352	VA	VA1DmdMax	Phase 1 VA demand maximum	01	60	Yes	Yes	Yes	Yes	Yes	Yes	--	Yes	Yes
178	30355	30354	VA	VA2DmdMax	Phase 2 VA demand maximum	01	62	Yes	Yes	Yes	No	Yes	Yes	--	Yes	Yes
179	30357	30356	VA	VA3DmdMax	Phase 3 VA demand maximum	01	64	Yes	Yes	No	No	Yes	Yes	--	Yes	Yes
180	30359	30358	%	VTHDAvg	Maximum average line to neutral voltage THD. *	01	66	Yes	Yes	Yes	Yes	Yes	Yes	--	Yes	Yes
181	30361	30360	%	VTHDAvg	Minimum average line to neutral voltage THD. *	01	68	Yes	Yes	Yes	Yes	Yes	Yes	--	Yes	Yes
182	30363	30362	%	ATHDAvg	Maximum average line current THD.	01	6A	Yes	Yes	Yes	Yes	Yes	Yes	--	Yes	Yes
183	30365	30364	%	ATHDAvg	Minimum average line current THD.	01	6C	Yes	Yes	Yes	Yes	Yes	Yes	--	Yes	Yes
184	30367	30366	Degrees	PA1Max	Maximum phase 1 phase angle.	01	6E	Yes	Yes	Yes	Yes	Yes	Yes	--	Yes	Yes

Parameter Number	Address	Register	Parameter Units	Parameter Name	Parameter Description	Modbus™ Start Address (Hex)		3P4W	3P3W	1P3W	1P2W	INT-2170	INT-2270	INT-1630	Alarm	Custom Log
						Hi Byte	Lo Byte									
185	30369	30368	Degrees	PA2Max	Maximum phase 2 phase angle.	01	70	Yes	Yes	Yes	No	Yes	Yes	--	Yes	Yes
186	30371	30370	Degrees	PA3Max	Maximum phase 3 phase angle.	01	72	Yes	Yes	No	No	Yes	Yes	--	Yes	Yes
187	30373	30372	Degrees	PA1Min	Minimum phase 1 phase angle.	01	74	Yes	Yes	Yes	Yes	Yes	Yes	--	Yes	Yes
188	30375	30374	Degrees	PA2Min	Minimum phase 2 phase angle.	01	76	Yes	Yes	Yes	No	Yes	Yes	--	Yes	Yes
189	30377	30376	Degrees	PA3Min	Minimum phase 3 phase angle.	01	78	Yes	Yes	No	No	Yes	Yes	--	Yes	Yes
190	30379	30378	Index	UScn1	Display User Screen 1	01	7A	Yes	Yes	Yes	Yes	Yes	Yes	--	No	No
191	30381	30380	Index	UScn2	Display User Screen 2	01	7C	Yes	Yes	Yes	Yes	Yes	Yes	--	No	No
192	30383	30382	Index	UScn3	Display User Screen 3	01	7E	Yes	Yes	Yes	Yes	Yes	Yes	--	No	No
193	30385	30384	Index	UScn4	Display User Screen 4	01	80	Yes	Yes	Yes	Yes	Yes	Yes	--	No	No
194	30387	30386	Index	UScn5	Display User Screen 5	01	82	Yes	Yes	Yes	Yes	Yes	Yes	--	No	No
195	30389	30388	Index	--	System Type	01	84	Yes	Yes	Yes	Yes	Yes	Yes	--	No	No
196	30391	30390	Index	--	Energy Prefix	01	86	Yes	Yes	Yes	Yes	Yes	Yes	--	No	No
197	30393	30392	Volts	--	System Line to Neutral Volts	01	88	Yes	Yes	Yes	Yes	Yes	Yes	--	Yes	Yes
198	30395	30394	Amps	--	System Amps	01	8A	Yes	Yes	Yes	Yes	Yes	Yes	--	No	No
199	30397	30396	Watts	--	System Volts x System Amps	01	8C	Yes	Yes	Yes	Yes	Yes	Yes	--	No	No
200	30399	30398	--	--	--	--	--	--	--	--	--	--	--	--	No	No
201	30401	30400	Always reads zero.	--	Blank Parameter Value.	01	90	Yes	Yes	Yes	Yes	Yes	Yes	--	No	No
202	30403	30402	Always reads one.	--	One, neutral range scaling.	01	92	Yes	Yes	Yes	Yes	Yes	Yes	--	No	No
203	30405	30404	Always reads zero.	--	Zero, zero range scaling.	01	94	Yes	Yes	Yes	Yes	Yes	Yes	--	No	No
204																
205																
206																
207																
208																
209																
210	30419	30418	Degrees	V1 Vector Angle	V1 vector angle	01	A2	Yes	Yes	Yes	Yes	No	Yes	--	No	No
211	30421	30420	Degrees	V2 Vector Angle	V2 vector angle	01	A4	Yes	Yes	Yes	No	No	Yes	--	No	No
212	30423	30422	Degrees	V3 Vector Angle	V3 vector angle	01	A6	Yes	Yes	No	No	No	Yes	--	No	No
213	30425	30424	Degrees	A1 Vector Angle	A1 vector angle	01	A8	Yes	Yes	Yes	Yes	No	Yes	--	No	No
214	30427	30426	Degrees	A2 Vector Angle	A2 vector angle	01	AA	Yes	Yes	Yes	No	No	Yes	--	No	No
215	30429	30428	Degrees	A3 Vector Angle	A3 vector angle	01	AC	Yes	Yes	No	No	No	Yes	--	No	No
250	30499	30498	Event Count	Cell A1	Sag class: 10 – 200ms & 90 – 80% Vref	01	F2	Yes	Yes	Yes	Yes	No	Yes	--	No	No
251	30501	30500	Event Count	Cell B1	Sag class: 10 – 200ms & 80 – 70% Vref	01	F4	Yes	Yes	Yes	Yes	No	Yes	--	No	No
252	30503	30502	Event Count	Cell C1	Sag class: 10 – 200ms & 70 – 40% Vref	01	F6	Yes	Yes	Yes	Yes	No	Yes	--	No	No
253	30505	30504	Event Count	Cell D1	Sag class: 10 – 200ms & 40 – 5% Vref	01	F8	Yes	Yes	Yes	Yes	No	Yes	--	No	No
254	30507	30506	Event Count	Cell X1	Sag class: 10 – 200ms & 5 – 0% Vref	01	FA	Yes	Yes	Yes	Yes	No	Yes	--	No	No
255	30509	30508	Event Count	Cell A2	Sag class: 200 – 500ms & 90 – 80% Vref	01	FC	Yes	Yes	Yes	Yes	No	Yes	--	No	No
256	30511	30510	Event Count	Cell B2	Sag class: 200 – 500ms & 80 – 70% Vref	01	FE	Yes	Yes	Yes	Yes	No	Yes	--	No	No
257	30513	30512	Event Count	Cell C2	Sag class: 200 – 500ms & 70 – 40% Vref	02	00	Yes	Yes	Yes	Yes	No	Yes	--	No	No
258	30515	30514	Event Count	Cell D2	Sag class: 200 – 500ms & 40 – 5% Vref	02	02	Yes	Yes	Yes	Yes	No	Yes	--	No	No
259	30517	30516	Event Count	Cell X2	Sag class: 200 – 500ms & 5 – 0% Vref	02	04	Yes	Yes	Yes	Yes	No	Yes	--	No	No
260	30519	30518	Event Count	Cell A3	Sag class: 0.5 – 1.0s & 90 – 80% Vref	02	06	Yes	Yes	Yes	Yes	No	Yes	--	No	No
261	30521	30520	Event Count	Cell B3	Sag class: 0.5 – 1.0s & 80 – 70% Vref	02	08	Yes	Yes	Yes	Yes	No	Yes	--	No	No
262	30523	30522	Event Count	Cell C3	Sag class: 0.5 – 1.0s & 70 – 40% Vref	02	0A	Yes	Yes	Yes	Yes	No	Yes	--	No	No
263	30525	30524	Event Count	Cell D3	Sag class: 0.5 – 1.0s & 40 – 5% Vref	02	0C	Yes	Yes	Yes	Yes	No	Yes	--	No	No
264	30527	30526	Event Count	Cell X3	Sag class: 0.5 – 1.0s & 5 – 0% Vref	02	0E	Yes	Yes	Yes	Yes	No	Yes	--	No	No
265	30529	30528	Event Count	Cell A4	Sag class: 1.0 – 5.0s & 90 – 80% Vref	02	10	Yes	Yes	Yes	Yes	No	Yes	--	No	No
266	30531	30530	Event Count	Cell B4	Sag class: 1.0 – 5.0s & 80 – 70% Vref	02	12	Yes	Yes	Yes	Yes	No	Yes	--	No	No
267	30533	30532	Event Count	Cell C4	Sag class: 1.0 – 5.0s & 70 – 40% Vref	02	14	Yes	Yes	Yes	Yes	No	Yes	--	No	No
268	30535	30534	Event Count	Cell D4	Sag class: 1.0 – 5.0s & 40 – 5% Vref	02	16	Yes	Yes	Yes	Yes	No	Yes	--	No	No
269	30537	30536	Event Count	Cell X4	Sag class: 1.0 – 5.0s & 5 – 0% Vref	02	18	Yes	Yes	Yes	Yes	No	Yes	--	No	No
270	30539	30538	Event Count	Cell A5	Sag class: 5.0 – 60s & 90 – 80% Vref	02	1A	Yes	Yes	Yes	Yes	No	Yes	--	No	No
271	30541	30540	Event Count	Cell B5	Sag class: 5.0 – 60s & 80 – 70% Vref	02	1C	Yes	Yes	Yes	Yes	No	Yes	--	No	No
272	30543	30542	Event Count	Cell C5	Sag class: 5.0 – 60s & 70 – 40% Vref	02	1E	Yes	Yes	Yes	Yes	No	Yes	--	No	No
273	30545	30544	Event Count	Cell D5	Sag class: 5.0 – 60s & 40 – 5% Vref	02	20	Yes	Yes	Yes	Yes	No	Yes	--	No	No
274	30547	30546	Event Count	Cell X5	Sag class: 5.0 – 60s & 5 – 0% Vref	02	22	Yes	Yes	Yes	Yes	No	Yes	--	No	No
275	30549	30548	Event Count	Cell A6	Sag class: over 60s & 90 – 80% Vref	02	24	Yes	Yes	Yes	Yes	No	Yes	--	No	No
276	30551	30550	Event Count	Cell B6	Sag class: over 60s & 80 – 70% Vref	02	26	Yes	Yes	Yes	Yes	No	Yes	--	No	No
277	30553	30552	Event Count	Cell C6	Sag class: over 60s & 70 – 40% Vref	02	28	Yes	Yes	Yes	Yes	No	Yes	--	No	No

Parameter Number	Address	Register	Parameter Units	Parameter Name	Parameter Description	Modbus™ Start Address (Hex)		3P4W	3P3W	1P3W	1P2W	INT-2170	INT-2270	INT-1630	Alarm	Custom Log
						Hi Byte	Lo Byte									
278	30555	30554	Event Count	Cell D6	Sag class: over 60s & 40 – 5% Vref	02	2A	Yes	Yes	Yes	Yes	No	Yes	--	No	No
279	30557	30556	Event Count	Cell X6	Sag class: over 60s & 5 – 0% Vref	02	2C	Yes	Yes	Yes	Yes	No	Yes	--	No	No
280	30559	30558	Event Count	Cell S1	Swell class: 10 – 500ms & over 120% Vref	02	2E	Yes	Yes	Yes	Yes	No	Yes	--	No	No
281	30561	30560	Event Count	Cell T1	Swell class: 10 – 500ms & 110 – 120% Vref	02	30	Yes	Yes	Yes	Yes	No	Yes	--	No	No
282	30563	30562	Event Count	Cell S2	Swell class: 0.5 – 5.0s & over 120% Vref	02	32	Yes	Yes	Yes	Yes	No	Yes	--	No	No
283	30565	30564	Event Count	Cell T2	Swell class: 0.5 – 5.0s & 110 – 120% Vref	02	34	Yes	Yes	Yes	Yes	No	Yes	--	No	No
284	30567	30566	Event Count	Cell S3	Swell class: 5.0 – 60s & over 120% Vref	02	36	Yes	Yes	Yes	Yes	No	Yes	--	No	No
285	30569	30568	Event Count	Cell T3	Swell class: 5.0 – 60s & 110 – 120% Vref	02	38	Yes	Yes	Yes	Yes	No	Yes	--	No	No
286	30571	30570	Event Count	Cell S4	Swell class: over 60s & over 120% Vref	02	3A	Yes	Yes	Yes	Yes	No	Yes	--	No	No
287	30573	30572	Event Count	Cell T4	Swell class: over 60s & 110 – 120% Vref	02	3C	Yes	Yes	Yes	Yes	No	Yes	--	No	No
300	30599	30598	%	--	Start of V1 harmonics table. 50 values	02	56	Yes	Yes	Yes	Yes	No	Yes	--	No	No
400	30799	30798	%	--	Start of V2 harmonics table. 50 values	03	1E	Yes	Yes	Yes	No	No	Yes	--	No	No
500	30999	30998	%	--	Start of V3 harmonics table. 50 values	30	00	Yes	Yes	No	No	No	Yes	--	No	No
600	31199	31198	%	--	Start of A1 harmonics table. 50 values	04	AE	Yes	Yes	Yes	Yes	No	Yes	--	No	No
700	31399	31398	%	--	Start of A2 harmonics table. 50 values	05	76	Yes	Yes	Yes	No	No	Yes	--	No	No
800	31599	31598	%	--	Start of A3 harmonics table. 50 values	06	3E	Yes	Yes	No	No	No	Yes	--	No	No
1000	31999	31998	ADC counts	--	Start of V1 waveform capture. 1024 values	07	CE	Yes	Yes	Yes	Yes	No	Yes	--	No	No
3000	35999	35998	ADC counts	--	Start of V2 waveform capture. 1024 values	17	6E	Yes	Yes	Yes	No	No	Yes	--	No	No
5000	39999	39998	ADC counts	--	Start of V3 waveform capture. 1024 values	27	0E	Yes	Yes	No	No	No	Yes	--	No	No
7000	43999	43998	ADC counts	--	Start of A1 waveform capture. 1024 values	36	AE	Yes	Yes	Yes	Yes	No	Yes	--	No	No
9000	47999	47998	ADC counts	--	Start of A2 waveform capture. 1024 values	46	4E	Yes	Yes	Yes	No	No	Yes	--	No	No
11000	51999	51998	ADC counts	--	Start of A3 waveform capture. 1024 values	55	EE	Yes	Yes	No	No	No	Yes	--	No	No
13000	55999	55998		DMD Psum Max TS	Maximum import power sum demand TimeStamp	65	8E	Yes	Yes	Yes	Yes	Yes	Yes	--	No	No
13002	56003	56002		DMD VAsum Max TS	Maximum Apparant Power sum demand TimeStamp	65	92	Yes	Yes	Yes	Yes	Yes	Yes	--	No	No
13004	56007	56006		DMD Asum Max TS	Maximum current sum demand TimeStamp	65	96	Yes	Yes	Yes	Yes	Yes	Yes	--	No	No
13006	56011	56010		V1 Max TS	Maximum phase 1 line to neutral voltage TimeStamp	65	9A	Yes	Yes	Yes	Yes	Yes	Yes	--	No	No
13008	56015	56014		V1 Min TS	Minimum phase 1 line to neutral voltage TimeStamp.	65	9E	Yes	Yes	Yes	Yes	Yes	Yes	--	No	No
13010	56019	56018		V2 Max TS	Maximum phase 2 line to neutral voltage TimeStamp.	65	A2	Yes	Yes	No	No	Yes	Yes	--	No	No
13012	56023	56022		V2 Min TS	Minimum phase 2 line to neutral voltage TimeStamp.	65	A6	Yes	Yes	No	No	Yes	Yes	--	No	No
13014	56027	56026		V3 Max TS	Maximum phase 3 line to neutral voltage TimeStamp.	65	AA	Yes	Yes	No	No	Yes	Yes	--	No	No
13016	56031	56030		V3 Min TS	Minimum phase 3 line to neutral voltage TimeStamp.	65	AE	Yes	Yes	No	No	Yes	Yes	--	No	No
13018	56035	56034		A1 Max TS	Maximum line 1 current TimeStamp.	65	B2	Yes	Yes	Yes	Yes	Yes	Yes	--	No	No
13020	56039	56038		A1 Min TS	Minimum line 1 current TimeStamp.	65	B6	Yes	Yes	Yes	Yes	Yes	Yes	--	No	No
13022	56043	56042		A2 Max TS	Maximum line 2 current TimeStamp.	65	BA	Yes	Yes	No	No	Yes	Yes	--	No	No
13024	56047	56046		A2 Min TS	Minimum line 2 current TimeStamp.	65	BE	Yes	Yes	No	No	Yes	Yes	--	No	No
13026	56051	56050		A3 Max TS	Maximum line 3 current TimeStamp.	65	C2	Yes	Yes	Yes	No	Yes	Yes	--	No	No
13028	56055	56054		A3 Min TS	Minimum line 3 current TimeStamp.	65	C6	Yes	Yes	Yes	No	Yes	Yes	--	No	No
13030	56059	56058		VLN Avg Max TS	Maximum average line to neutral voltage TimeStamp.	65	CA	Yes	No	No	No	Yes	Yes	--	No	No
13032	56063	56062		VLN Avg Min TS	Minimum average line to neutral voltage TimeStamp.	65	CE	Yes	No	No	No	Yes	Yes	--	No	No
13034	56067	56066		Aavg Max TS	Maximum Average Current TimeStamp	65	D2	Yes	Yes	Yes	Yes	Yes	Yes	--	No	No
13036	56071	56070		Aavg Min TS	Minimum Average Current TimeStamp	65	D6	Yes	Yes	Yes	Yes	Yes	Yes	--	No	No
13038	56075	56074		Asum Max TS	Maximum Sum of phase currents TimeStamp	65	DA	Yes	Yes	Yes	Yes	Yes	Yes	--	No	No
13040	56079	56078		Asum Min TS	Minimum Sum of phase currents TimeStamp	65	DE	Yes	Yes	Yes	Yes	Yes	Yes	--	No	No
13042	56083	56082		P1 Max TS	Maximum phase 1 power TimeStamp.	65	00	Yes	Yes	Yes	Yes	Yes	Yes	--	No	No
13044	56087	56086		P1 Min TS	Minimum phase 1 power TimeStamp.	65	00	Yes	Yes	Yes	Yes	Yes	Yes	--	No	No
13046	56091	56090		P2 Max TS	Maximum phase 2 power TimeStamp.	65	EA	Yes	Yes	No	No	Yes	Yes	--	No	No
13048	56095	56094		P2 Min TS	Minimum phase 2 power TimeStamp.	65	EE	Yes	Yes	No	No	Yes	Yes	--	No	No
13050	56099	56098		P3 Max TS	Maximum phase 3 power TimeStamp.	65	F2	Yes	Yes	No	No	Yes	Yes	--	No	No
13052	56103	56102		P3 Min TS	Minimum phase 3 power TimeStamp.	65	F6	Yes	Yes	No	No	Yes	Yes	--	No	No
13054	56107	56106		PSum Max TS	Maximum Sum of phase powers TimeStamp	65	FA	Yes	Yes	Yes	Yes	Yes	Yes	--	No	No
13056	56111	56110		Psum Min TS	Minimum Sum of phase powers TimeStamp	65	FE	Yes	Yes	Yes	Yes	Yes	Yes	--	No	No
13058	56115	56114		VAr1 Max TS	Maximum phase 1 VArS TimeStamp.	66	02	Yes	Yes	Yes	Yes	Yes	Yes	--	No	No
13060	56119	56118		VAr1 Min TS	Minimum phase 1 VArS TimeStamp.	66	06	Yes	Yes	Yes	Yes	Yes	Yes	--	No	No
13062	56123	56122		VAr2 Max TS	Maximum phase 2 VArS TimeStamp.	66	0A	Yes	Yes	No	No	Yes	Yes	--	No	No
13064	56127	56126		VAr2 Min TS	Minimum phase 2 VArS TimeStamp.	66	0E	Yes	Yes	No	No	Yes	Yes	--	No	No
13066	56131	56130		VAr3 Max TS	Maximum phase 3 VArS TimeStamp.	66	12	Yes	Yes	No	No	Yes	Yes	--	No	No
13068	56135	56134		VAr3 Min TS	Minimum phase 3 VArS TimeStamp.	66	16	Yes	Yes	No	No	Yes	Yes	--	No	No
13070	56139	56138		VArSum Max TS	Maximum Sum of phase VArS TimeStamp	66	1A	Yes	Yes	Yes	Yes	Yes	Yes	--	No	No
13072	56143	56142		VArSum Min TS	Minimum Sum of phase VArS TimeStamp	66	1E	Yes	Yes	Yes	Yes	Yes	Yes	--	No	No
13074	56147	56146		VA1 Max TS	Maximum phase 1 VA TimeStamp.	66	22	Yes	Yes	Yes	Yes	Yes	Yes	--	No	No
13076	56151	56150		VA1 Min TS	Minimum phase 1 VA TimeStamp.	66	26	Yes	Yes	Yes	Yes	Yes	Yes	--	No	No
13078	56155	56154		VA2 Max TS	Maximum phase 2 VA TimeStamp.	66	2A	Yes	Yes	No	No	Yes	Yes	--	No	No

Parameter Number	Address	Register	Parameter Units	Parameter Name	Parameter Description	Modbus™ Start Address (Hex)		3P4W	3P3W	1P3W	1P2W	INT-2170	INT-2270	INT-1630	Alarm	Custom Log
						Hi Byte	Lo Byte									
13080	56159	56158		VA2 Min TS	Minimum phase 2 VA TimeStamp.	66	2E	Yes	Yes	No	No	Yes	Yes	--	No	No
13082	56163	56162		VA3 Max TS	Maximum phase 3 VA TimeStamp.	66	32	Yes	Yes	No	No	Yes	Yes	--	No	No
13084	56167	56166		VA3 Min TS	Minimum phase 3 VA TimeStamp.	66	36	Yes	Yes	No	No	Yes	Yes	--	No	No
13086	56171	56170		VASum Max TS	Maximum Sum of phase VA TimeStamp	66	3A	Yes	Yes	Yes	Yes	Yes	Yes	--	No	No
13088	56175	56174		VASum Min TS	Minimum Sum of phase VA TimeStamp	66	3E	Yes	Yes	Yes	Yes	Yes	Yes	--	No	No
13090	56179	56178		Frequency Max TS	Maximum Frequency TimeStamp	66	42	Yes	Yes	Yes	Yes	Yes	Yes	--	No	No
13092	56183	56182		Frequency Min TS	Minimum Frequency TimeStamp	66	46	Yes	Yes	Yes	Yes	Yes	Yes	--	No	No
13094	56187	56186		V12 Max TS	Maximum line 1 to line 2 voltage TimeStamp.	66	4A	Yes	Yes	Yes	Yes	Yes	Yes	--	No	No
13096	56191	56190		V12 Min TS	Minimum line 1 to line 2 voltage TimeStamp.	66	4E	Yes	Yes	Yes	No	Yes	Yes	--	No	No
13098	56195	56194		V23 Max TS	Maximum line 2 to line 3 voltage TimeStamp.	66	52	Yes	Yes	No	No	Yes	Yes	--	No	No
13100	56199	56198		V23 Min TS	Minimum line 2 to line 3 voltage TimeStamp.	66	56	Yes	Yes	No	No	Yes	Yes	--	No	No
13102	56203	56202		V31 Max TS	Maximum line 3 to line 1 voltage TimeStamp.	66	5A	Yes	Yes	No	No	Yes	Yes	--	No	No
13104	56207	56206		V31 Min TS	Minimum line 3 to line 1 voltage TimeStamp.	66	5E	Yes	Yes	No	No	Yes	Yes	--	No	No
13106	56211	56210		VLL Avg Max TS	Maximum Average V L-L TimeStamp	66	62	Yes	Yes	No	No	Yes	Yes	--	No	No
13108	56215	56214		VLL Avg Min TS	Minimum Average V L-L TimeStamp	66	66	Yes	Yes	No	No	Yes	Yes	--	No	No
13110	56219	56218		An Max TS	Maximum Neutral current TimeStamp	66	6A	Yes	No	No	Yes	Yes	Yes	--	No	No
13112	56223	56222		An Min TS	Minimum Neutral current TimeStamp	66	6E	Yes	No	No	Yes	Yes	Yes	--	No	No
13114	56227	56226		DMD An Max TS	Maximum Neutral Current Demand TimeStamp	66	72	Yes	Yes	Yes	Yes	Yes	Yes	--	No	No
13116	56231	56230		DMD A1 Max TS	Maximum Phase1 Current Demand TimeStamp	66	76	Yes	Yes	Yes	Yes	Yes	Yes	--	No	No
13118	56235	56234		DMD A2 Max TS	Maximum Phase2 Current Demand TimeStamp	66	7A	Yes	Yes	Yes	No	Yes	Yes	--	No	No
13120	56239	56238		DMD A3 Max TS	Maximum Phase3 Current Demand TimeStamp	66	7E	Yes	Yes	No	No	Yes	Yes	--	No	No
13122	56243	56242		VLN Unbalanced Max TS	Maximum V L-N Unbalanced TimeStamp	66	82	Yes	No	No	No	Yes	Yes	--	No	No
13124	56247	56246		VLN Unbalanced Min TS	Minimum V L-N Unbalanced TimeStamp	66	86	Yes	No	No	No	Yes	Yes	--	No	No
13126	56251	56250		VLL Unbalanced Max TS	Maximum V L-L Unbalanced TimeStamp	66	8A	Yes	Yes	No	No	Yes	Yes	--	No	No
13128	56255	56254		VLL Unbalanced Min TS	Minimum V L-L Unbalanced TimeStamp	66	8E	Yes	Yes	No	No	Yes	Yes	--	No	No
13130	56259	56258		A Unbalance Max TS	Maximum Current Unbalanced TimeStamp	66	92	Yes	Yes	Yes	Yes	Yes	Yes	--	No	No
13132	56263	56262		A Unbalance Min TS	Minimum Current Unbalanced TimeStamp	66	96	Yes	Yes	Yes	Yes	Yes	Yes	--	No	No
13134	56267	56266		PF1 Max TS	Maximum phase 1 power factor TimeStamp.	66	9A	Yes	Yes	Yes	Yes	Yes	Yes	--	No	No
13136	56271	56270		PF1 Min TS	Minimum phase 1 power factor TimeStamp.	66	9E	Yes	Yes	Yes	Yes	Yes	Yes	--	No	No
13138	56275	56274		PF2 Max TS	Maximum phase 2 power factor TimeStamp.	66	A2	Yes	Yes	No	No	Yes	Yes	--	No	No
13140	56279	56278		PF2 Min TS	Minimum phase 2 power factor TimeStamp.	66	A6	Yes	Yes	No	No	Yes	Yes	--	No	No
13142	56283	56282		PF3 Max TS	Maximum phase 3 power factor TimeStamp.	66	AA	Yes	Yes	No	No	Yes	Yes	--	No	No
13144	56287	56286		PF3 Min TS	Minimum phase 3 power factor TimeStamp.	66	AE	Yes	Yes	No	No	Yes	Yes	--	No	No
13146	56291	56290		PFTot Max TS	Maximum total system power factor TimeStamp.	66	B2	Yes	Yes	Yes	Yes	Yes	Yes	--	No	No
13148	56295	56294		PFTot Min TS	Minimum total system power factor TimeStamp.	66	B6	Yes	Yes	Yes	Yes	Yes	Yes	--	No	No
13150	56299	56298		PATot Max TS	Maximum total system phase angle TimeStamp.	66	BA	Yes	Yes	Yes	Yes	Yes	Yes	--	No	No
13152	56303	56302		PATot Min TS	Minimum total system phase angle TimeStamp.	66	BE	Yes	Yes	Yes	Yes	Yes	Yes	--	No	No
13154	56307	56306		Har V1 THD Max TS	Maximum V1 THD TimeStamp	66	C2	Yes	Yes	Yes	Yes	Yes	Yes	--	No	No
13156	56311	56310		Har V1 THD Min TS	Minimum V1 THD TimeStamp	66	C6	Yes	Yes	Yes	Yes	Yes	Yes	--	No	No
13158	56315	56314		Har V2 THD Max TS	Maximum V2 THD TimeStamp	66	CA	Yes	Yes	No	No	Yes	Yes	--	No	No
13160	56319	56318		Har V2 THD Min TS	Minimum V2 THD TimeStamp	66	CE	Yes	Yes	No	No	Yes	Yes	--	No	No
13162	56323	56322		Har V3 THD Max TS	Maximum V3 THD TimeStamp	66	D2	Yes	Yes	No	No	Yes	Yes	--	No	No
13164	56327	56326		Har V3 THD Min TS	Minimum V3 THD TimeStamp	66	D6	Yes	Yes	No	No	Yes	Yes	--	No	No
13166	56331	56330		Har A1 THD Max TS	Maximum A1 THD TimeStamp	66	DA	Yes	Yes	Yes	Yes	Yes	Yes	--	No	No
13168	56335	56334		Har A1 THD Min TS	Minimum A1 THD TimeStamp	66	DE	Yes	Yes	Yes	Yes	Yes	Yes	--	No	No
13170	56339	56338		Har A2 THD Max TS	Maximum A2 THD TimeStamp	66	00	Yes	Yes	No	No	Yes	Yes	--	No	No
13172	56343	56342		Har A2 THD Min TS	Minimum A2 THD TimeStamp	66	00	Yes	Yes	No	No	Yes	Yes	--	No	No
13174	56347	56346		Har A3 THD Max TS	Maximum A3 THD TimeStamp	66	EA	Yes	Yes	No	No	Yes	Yes	--	No	No
13176	56351	56350		Har A3 THD Min TS	Minimum A3 THD TimeStamp	66	EE	Yes	Yes	No	No	Yes	Yes	--	No	No
13178	56355	56354		DMD P1 Max TS	Import phase 1 power demand maximum TimeStamp. TimeStamp.	66	F2	Yes	Yes	Yes	Yes	Yes	Yes	--	No	No
13180	56359	56358		DMD P2 Max TS	Import phase 2 power demand maximum TimeStamp. TimeStamp.	66	F6	Yes	Yes	Yes	No	Yes	Yes	--	No	No
13182	56363	56362		DMD P3 Max TS	Import phase 3 power demand maximum TimeStamp. TimeStamp.	66	FA	Yes	Yes	No	No	Yes	Yes	--	No	No
13184	56367	56366		DMD VA1 Max TS	Phase 1 VA demand maximum TimeStamp.	66	FE	Yes	Yes	Yes	Yes	Yes	Yes	--	No	No
13186	56371	56370		DMD VA2 Max TS	Phase 2 VA demand maximum TimeStamp.	67	02	Yes	Yes	Yes	No	Yes	Yes	--	No	No
13188	56375	56374		DMD VA3 Max TS	Phase 3 VA demand maximum TimeStamp.	67	06	Yes	Yes	No	No	Yes	Yes	--	No	No
13190	56379	56378		Har VL-Navg THD Max TS	Maximum V L-N Average THD TimeStamp	67	0A	Yes	No	No	No	Yes	Yes	--	No	No
13192	56383	56382		Har VL-Navg THD Min TS	Minimum V L-N Average THD TimeStamp	67	0E	Yes	No	No	No	Yes	Yes	--	No	No
13194	56387	56386		Har Aavg THD Max TS	Maximum Current Average THD TimeStamp	67	12	Yes	Yes	Yes	Yes	Yes	Yes	--	No	No
13196	56391	56390		Har Aavg THD Min TS	Minimum Current Average THD TimeStamp	67	16	Yes	Yes	Yes	Yes	Yes	Yes	--	No	No
13198	56395	56394		PA1 Max TS	Maximum phase 1 phase angle TimeStamp.	67	1A	Yes	Yes	Yes	Yes	Yes	Yes	--	No	No
13200	56399	56398		PA2 Max TS	Maximum phase 2 phase angle TimeStamp.	67	1E	Yes	Yes	Yes	Yes	Yes	Yes	--	No	No
13202	56403	56402		PA3 Max TS	Maximum phase 3 phase angle TimeStamp.	67	22	Yes	Yes	Yes	Yes	Yes	Yes	--	No	No

Parameter Number	Address	Register	Parameter Units	Parameter Name	Parameter Description	Modbus™ Start Address (Hex)		3P4W	3P3W	1P3W	1P2W	INT-2170	INT-2270	INT-1630	Alarm	Custom Log
						Hi Byte	Lo Byte									
13204	56407	56406		PA1 Min TS	Minimum phase 1 phase angle TimeStamp.	67	26	Yes	Yes	Yes	Yes	Yes	Yes	--	No	No
13206	56411	56410		PA2 Min TS	Minimum phase 2 phase angle TimeStamp.	67	2A	Yes	Yes	Yes	Yes	Yes	Yes	--	No	No
13208	56415	56414		PA3 Min TS	Minimum phase 3 phase angle TimeStamp.	67	2E	Yes	Yes	Yes	Yes	Yes	Yes	--	No	No
13210	56419	56418		ALM Direct Output TS 0	Alarm 1 TimeStamp	67	32	Yes	Yes	Yes	Yes	Yes	Yes	--	No	No
13212	56423	56422		ALM Direct Output TS 1	Alarm 2 TimeStamp	67	36	Yes	Yes	Yes	Yes	Yes	Yes	--	No	No
13214	56427	56426		ALM Direct Output TS 2	Alarm 3 TimeStamp	67	3A	Yes	Yes	Yes	Yes	Yes	Yes	--	No	No
13216	56431	56430		ALM Direct Output TS 3	Alarm 4 TimeStamp	67	3E	Yes	Yes	Yes	Yes	Yes	Yes	--	No	No
13218	56435	56434		ALM Direct Output TS 4	Alarm 5 TimeStamp	67	42	Yes	Yes	Yes	Yes	Yes	Yes	--	No	No
13220	56439	56438		ALM Direct Output TS 5	Alarm 6 TimeStamp	67	46	Yes	Yes	Yes	Yes	Yes	Yes	--	No	No
13222	56443	56442		ALM Latched Output TS 0	Latched Alarm 1 TimeStamp	67	4A	Yes	Yes	Yes	Yes	Yes	Yes	--	No	No
13224	56447	56446		ALM Latched Output TS 1	Latched Alarm 2 TimeStamp	67	4E	Yes	Yes	Yes	Yes	Yes	Yes	--	No	No
13226	56451	56450		ALM Latched Output TS 2	Latched Alarm 3 TimeStamp	67	52	Yes	Yes	Yes	Yes	Yes	Yes	--	No	No
13228	56455	56454		ALM Latched Output TS 3	Latched Alarm 4 TimeStamp	67	56	Yes	Yes	Yes	Yes	Yes	Yes	--	No	No
13230	56459	56458		ALM Latched Output TS 4	Latched Alarm 5 TimeStamp	67	5A	Yes	Yes	Yes	Yes	Yes	Yes	--	No	No
13232	56463	56462		ALM Latched Output TS 5	Latched Alarm 6 TimeStamp	67	5E	Yes	Yes	Yes	Yes	Yes	Yes	--	No	No
13234	56467	56466		EGY Energy Reset TS	Last Energy Reset TimeStamp	67	62	Yes	Yes	Yes	Yes	Yes	Yes	--	No	No
13236	56471	56470		DMD Reset All TS	Last Reset Demand All TimeStamp	67	66	Yes	Yes	Yes	Yes	Yes	Yes	--	No	No
13238	56475	56474		DMD Reset Max TS	Last Maximum Demand Reset TimeStamp	67	6A	Yes	Yes	Yes	Yes	Yes	Yes	--	No	No
13240	56479	56478		EGY Reset Hours Run Flag TS	Last Hours Run reset TimeStamp	67	6E	Yes	Yes	Yes	Yes	Yes	Yes	--	No	No
13242	56483	56482		Max Min Reset TS	Last Max Min reset TimeStamp	67	72	Yes	Yes	Yes	Yes	Yes	Yes	--	No	No
13244	56487	56486		Har Max Min Reset Flag TS	Last Max Min Harmonics Reset TimeStamp	67	76	Yes	Yes	Yes	Yes	Yes	Yes	--	No	No
13246	56491	56490		SagSwell Reset Flag TS	Last Sag/Swell Reset TimeStamp	67	7A	Yes	Yes	Yes	Yes	Yes	Yes	--	No	No
13248	56495	56494		PIP Reset Pulse Input Counts TS	Lats Pulsed Input Rest TimeStamp	67	7E	Yes	Yes	Yes	Yes	Yes	Yes	--	No	No
13250	56499	56498		ALM Soft Alarm Latch Reset	Last Soft Alarm latch reset TimeStamp	67	82	Yes	Yes	Yes	Yes	Yes	Yes	--	No	No
13252	56503	56502		MB All Eeprom Reset	Last EEPROM reset	67	86	Yes	Yes	Yes	Yes	Yes	Yes	--	No	No
13254	56507	56506		NVM Factory Reset	Last Non volatile memory reset	67	8A	Yes	Yes	Yes	Yes	Yes	Yes	--	No	No
13256	56511	56510		SYS Power Off	Last System Power Off	67	8E	Yes	Yes	Yes	Yes	Yes	Yes	--	No	No
13258	56515	56514		Sys Power On	Last System Power On	67	92	Yes	Yes	Yes	Yes	Yes	Yes	--	No	No
13260	56519	56518		Sys Current		67	96	Yes	Yes	Yes	Yes	Yes	Yes	--	No	No

5 APPENDIX 2 - INTEGRA, INT-2270 / INT-2170 MODBUS™ HOLDING Register Parameters

Parameter Number	Register	Address	Parameter Units	Parameter Name	Parameter Description	Modbus™ Start Address (Hex)		3P4W	3P3W	1P3W	1P2W	Valid Range	Default	Mode
						Hi Byte	Lo Byte							
1	40001	40000	Minutes	Demand Time	Read - Minutes into first demand calculation.	00	00	Yes	Yes	Yes	Yes	0		ro
2	40003	40002	Minutes	Demand Period	Write - Demand period in minutes. see SYS_MINUTES_U8DEF for default value.	00	02	Yes	Yes	Yes	Yes	0, 2, 5, 8, 10, 15, 20, 30 and 60 minutes.	30	r/w
3	40005	40004	0,1	Balanced System	Write - 1 for a balanced system type, default zero.	00	04	Yes	No	No	No	0: Unbalanced. 1: Balanced.	0	r/w
4	40007	40006	Volts	System Volts	Write - system voltage, VLL for 3P3W, VLN for others. See SYS_SYSTEM_VOLTS_LN_x_F32DEF, SYS_SYSTEM_VOLTS_LL_x_F32DEF and SYS_SYSTEM_VLN_1P3W_x_F32DEF for default value, also subject to power limit. x = 0, 1 or 2.	00	06	Yes	Yes	Yes	Yes	1 to 999kV. VLL for 3P3W, VLN for others. See SYS_SYSTEM_VOLTS_LN_x_F32DEF, SYS_SYSTEM_VOLTS_LL_x_F32DEF and SYS_SYSTEM_VLN_1P3W_x_F32DEF for default value, also subject to power limit. x = 0, 1 or 2.	Sec V Max	r/w
5	40009	40008	Amps	System Amps	Write -system current, see SYS_SYSTEM_AMPS_F32DEF for default value, also subject to power limit.	00	08	Yes	Yes	Yes	Yes	1 to 9999MA.	1 or 5	r/w
6	40011	40010	Index	System Type	Write - system type, see SYS_SYSTEM_TYPE_U16DEF for default value.	00	0A	Yes	Yes	Yes	Yes	1: 1P2W, 2: 3P3W, 3: 3P4W and 4: 1P3W.	3	r/w
7	40013	40012	milliseconds	Relay Pulse Width	Write -relay on period in milliseconds, see SYS_PULSEWIDTH_U8DEF for default value in 20ms units.	00	0C	Yes	Yes	Yes	Yes	60ms, 100ms or 200ms.	200ms	r/w
8	40015	40014	Index	Password Lock	Write- any value to password lock protected registers. Read password lock status: 0 = locked. 1 = Factory password locked, user password unlocked. 2 = Factory password unlocked, user password locked. 3 = Factory password unlocked, user password unlocked. Also, reading will reset the user password timeout back to one minute.	00	0E	Yes	Yes	Yes	Yes	0: Instrument locked 1: User password entered 2: Factory password entered. 3: Both User and Factory passwords entered. Write any value to lock instrument.	0	r/w
12	40023	40022	Index	Relay Pulse Divisor	Write- pulse divisor index n, as in Wh/10^n. See SYS_PULSEDIVISOR_U8DEF for default value.	00	16	Yes	Yes	Yes	Yes	0 to 14 e.g. 0: One pulse per 1Wh, 3: One pulse per 1kWh, 6: One pulse per 1MWh	3	r/w
13	40025	40024	Numerical	Password	Read/Write- Read zero, or User Password if factory password unlocked. Write password for access to protected registers. See SYS_USERPASSWORD_U16DEF for values. U Write new user password, 10000 to 19999, if user password unlocked. Note, the leading 1 is to further distinguish selecting a new user password from user password entry. Also, reading will reset the user password timeout back to one minute.	00	18	Yes	Yes	Yes	Yes	Write user password to access U parameters. Write factory password to access F parameters. Read zero.	0	wo
13	40025	40024	Numerical	Password	Read/Write- Read zero, or User Password if factory password unlocked. Write password for access to protected registers. See SYS_USERPASSWORD_U16DEF for values. U Write new user password, 10000 to 19999, if user password unlocked. Note, the leading 1 is to further distinguish selecting a new user password from user password entry. Also, reading will reset the user password timeout back to one minute.	00	18	ü	ü	ü	ü	Write new user password, in the form 1NNNN Read zero.	0	wo
16	40031	40030	Index	Energy Units Prefix	Write- the units prefix for energy output, see SYS_ENERGYPREFIX_U8DEF for default value. 0 = None, e.g. Wh. But mAh for ampere hours. 1 = k, e.g. kWh, default. But Ah for ampere hours. 2 = M, e.g. MWh. But kWh for ampere hours.	00	1E	Yes	Yes	Yes	Yes	0: None, e.g. Wh, but mAh. 1: k, e.g. kWh, but Ah. 2: M, e.g. MWh, but kWh. 3: G, e.g. GWh, but MAh.	1	r/w
17	40033	40032	0,1	Low Power Flag	Write- the low level power flag. 0 = No limit. 1 = Selected limit, parameter 144, default.	00	20	Yes	Yes	Yes	Yes	0: No limit. 1: Selected limit.	1	r/w
19	40037	40036	Watts	System Power	Read- The total system power. e.g. for 3p4w, returns Vsys * Isys * 3.	00	24	Yes	Yes	Yes	Yes	Read the total system power, e.g. for 3 phase 4 wire, returns System Volts x System Amps x 3.		ro
20	40039	40038		System Power										
25	40049	40048				00	30							
26	40051	40050		Product Serial Number Part 1		00	32							
27	40053	40052		Product Serial Number Part 2		00	34							
28	40055	40054		Low Phase Angle Flag		00	36							
29	40057	40056				00	38							
30	40059	40058	Volts	Voltage Measurement Range	Read/Write - Voltage measurement range index.	00	3A	Yes	Yes	Yes	Yes	0: 139V LN (240V LL). 1: 277V LN (480V LL). 2: 346V LN (600V LL).	0	r/w
31	40061	40060	Amps	Current Measurement Range	Read/Write - Current measurement range index.	00	3C	Yes	Yes	Yes	Yes	0: 1A. 1: 5A.	0	r/w
33	40065	40064	Amps	Input Current Gain	Read - the index for the actual input current gain. 0: Current gain is x1. 1: Current gain is x2. 2: Current gain is x4. 3: Current gain is x8. 4: Current gain is x32.	00	40	Yes	Yes	Yes	Yes	0: Current gain is x1. 1: Current gain is x2. 2: Current gain is x4. 3: Current gain is x8. 4: Current gain is x32.	None	ro
34	40067	40066	Amps	Input Current Pot Setting	Read - the number of times the gain has changed.	00	42	Yes	Yes	Yes	Yes	Counter rolls over to zero after 255.	None	ro
35	40069	40068		Voltage Measurement Range		00	44							
36	40071	40070	0,1	Current Measurement Range	Read/Write Relay 1 Latching Mode.	00	46	Yes	Yes	Yes	Yes	0: Non Latching. 1: Latching.	0	r/w
37	40073	40072	0,1	Relay 2 Latching Mode	Read/Write Relay 2 Latching Mode.	00	48	Yes	Yes	Yes	Yes	0: Non Latching. 1: Latching.	0	r/w
38	40075	40074				00	4A							
39	40077	40076				00	4C							

40	40079	40078				00	4E										
41	40081	40080				00	50										
42	40083	40082	Index	Relay 1 Function Index	Write - Write relay 1 function code. 0: Pulse output relay. 1: Normally open alarm 1 relay. 2: Normally closed alarm 1 relay. 3: Relay disabled.	00	52	Yes	Yes	Yes	Yes			0: Pulse output relay. 1: Normally open alarm 1 relay. 2: Normally closed alarm 1 relay. 3: Relay disabled.	0	r/w	
43	40085	40084	Index	Relay 2 Function Index	Write - Write relay 2 function code. 0: Pulse output relay. 1: Normally open alarm 2 relay. 2: Normally closed alarm 2 relay. 3: Relay disabled.	00	54	Yes	Yes	Yes	Yes			0: Pulse output relay. 1: Normally open alarm 2 relay. 2: Normally closed alarm 2 relay. 3: Relay disabled.	0	r/w	
44	40087	40086	Index	Relay 1 Energy Index	Write - Write Modbus input parameter for pulse relay 1. See SYS_RELAY_SOURCE0_U8DEF for default value.	00	56	Yes	Yes	Yes	Yes			0: Disable pulses. 37: Import Wh. 38: Export Wh. 39: Import VAh. 40: Export VAh.	37	r/w	
45	40089	40088	Index	Relay 2 Energy Index	Write - Modbus input parameter for pulse relay 2. See SYS_RELAY_SOURCE1_U8DEF for default value.	00	58	Yes	Yes	Yes	Yes			0: Disable pulses. 37: Import Wh. 38: Export Wh. 39: Import VAh. 40: Export VAh.	39	r/w	
46	40091	40090	0,1	Relay 1 Latch Mode	Write - Relay 1 latch mode. 0: Relay 1 not latching. 1: Relay 1 latching.	00	5A	Yes	Yes	Yes	Yes			0: Non-Latching. 1: Latching.	0	r/w	
47	40093	40092	0,1	Relay 2 Latch Mode	Write - Relay 2 latch mode. 0: Relay 2 not latching. 1: Relay 2 latching.	00	5C	Yes	Yes	Yes	Yes			0: Non-Latching. 1: Latching.	0	r/w	
48	40095	40094				00	5E										
49	40097	40096				00	60										
50	40099	40098				00	62										
51	40101	40100	VA	VA Limit For Hours Run	Write - the proportion of nominal VA to enable Hours Run to operate, see SYS_VALIMITFORHOURS_RUN_F32DEF for default value.	00	64	Yes	Yes	Yes	Yes			Minimum: 0.0, Maximum: 1.44	0.1	r/w	
60	40119	40118	Index	Pulse Input 1 Edge	Write- pulse input 1 edge code. 0: Rising edge. 1: Falling edge. 2: Both edges.	00	76	Yes	Yes	Yes	Yes			0: Rising edge. 1: Falling edge. 2: Both edges.	0	r/w	
61	40121	40120	Index	Pulse Input 2 Edge	Write- pulse input 2 edge code. 0: Rising edge. 1: Falling edge. 2: Both edges.	00	78	Yes	Yes	Yes	Yes			0: Rising edge. 1: Falling edge. 2: Both edges.	0	r/w	
62	40123	40122	Index	Alarm 1 Input Parameter	Write- alarm 1 input parameter.	00	7A	Yes	Yes	Yes	Yes			0 to 255. Check with Input parameter table.	0	r/w	
63	40125	40124	Value	Alarm 1 Trip Level	Write- alarm 1 parameter trip level.	00	7C	Yes	Yes	Yes	Yes			Any value in the selected parameters range.	0	r/w	
64	40127	40126	Value	Alarm 1 Release Level	Write- alarm 1 parameter release level.	00	7E	Yes	Yes	Yes	Yes			Any value in the selected parameters range.	0	r/w	
65	40129	40128	Seconds	Alarm 1 Delay Seconds	Read/Write - Write alarm 1 delay to trip (seconds).	00	80	Yes	Yes	Yes	Yes			0.0 to 600.0 seconds	0	r/w	
66	40131	40130	0,1	Alarm 1 Direct Output	Read - direct alarm 1 output. 0: No alarm trip. 1: Alarm tripped.	00	82	Yes	Yes	Yes	Yes			0: No alarm trip. 1: Alarm tripped.		ro	
67	40133	40132	0,1	Alarm 1 Latched Output	Read - latched alarm 1 output. 0: Alarm not latched. 1: Alarm latched, write zero to clear latch.	00	84	Yes	Yes	Yes	Yes			0: No alarm trip. 1: Alarm tripped.		ro	
68	40135	40134	Index	Alarm 2 Input Parameter	Write- alarm 2 input parameter.	00	86	Yes	Yes	Yes	Yes			0 to 255. Check with Input parameter table.	0	r/w	
69	40137	40136	Value	Alarm 2 Trip Level	Write- alarm 2 parameter trip level.	00	88	Yes	Yes	Yes	Yes			Any value in the selected parameters range.	0	r/w	
70	40139	40138	Value	Alarm 2 Release Level	Write- alarm 2 parameter release level.	00	8A	Yes	Yes	Yes	Yes			Any value in the selected parameters range.	0	r/w	
71	40141	40140	Seconds	Alarm 2 Delay Seconds	Write- alarm 2 delay to trip (seconds).	00	8C	Yes	Yes	Yes	Yes			0.0 to 600.0 seconds	0	r/w	
72	40143	40142	0,1	Alarm 2 Direct Output	Read- direct alarm 2 output. 0: No alarm trip. 1: Alarm tripped.	00	8E	Yes	Yes	Yes	Yes			0: No alarm trip. 1: Alarm tripped.		ro	
73	40145	40144	0,1	Alarm 2 Latched Output	Read - latched alarm 2 output. 0: Alarm not latched. 1: Alarm latched, write zero to clear latch.	00	90	Yes	Yes	Yes	Yes			0: No alarm trip. 1: Alarm tripped.		ro	
74	40147	40146	Index	Alarm 3 Input Parameter	Write- alarm 3 input parameter.	00	92	Yes	Yes	Yes	Yes			0 to 255. Check with Input parameter table.	0	r/w	
75	40149	40148	Value	Alarm 3 Trip Level	Write- alarm 3 parameter trip level.	00	94	Yes	Yes	Yes	Yes			Any value in the selected parameters range.	0	r/w	
76	40151	40150	Value	Alarm 3 Release Level	Write- alarm 3 parameter release level.	00	96	Yes	Yes	Yes	Yes			Any value in the selected parameters range.	0	r/w	
77	40153	40152	Seconds	Alarm 3 Delay Seconds	Write- alarm 3 delay to trip (seconds).	00	98	Yes	Yes	Yes	Yes			0.0 to 600.0 seconds	0	r/w	
78	40155	40154	0,1	Alarm 3 Direct Output	Read- direct alarm 3 output. 0: No alarm trip. 1: Alarm tripped.	00	9A	Yes	Yes	Yes	Yes			0: No alarm trip. 1: Alarm tripped.		ro	
79	40157	40156	0,1	Alarm 3 Latched Output	Read- latched alarm 3 output. 0: Alarm not latched. 1: Alarm latched, write zero to clear latch.	00	9C	Yes	Yes	Yes	Yes			0: No alarm trip. 1: Alarm tripped.		ro	
80	40159	40158	Index	Alarm 4 Input Parameter	Write- alarm 4 input parameter.	00	9E	Yes	Yes	Yes	Yes			0 to 255. Check with Input parameter table.	0	r/w	

81	40161	40160	Value	Alarm 4 Trip Level	Write- alarm 4 parameter trip level.	00	A0	Yes	Yes	Yes	Yes	Any value in the selected parameters range.	0	r/w
82	40163	40162	Value	Alarm 4 Release Level	Write- alarm 4 parameter release level.	00	A2	Yes	Yes	Yes	Yes	Any value in the selected parameters range.	0	r/w
83	40165	40164	Seconds	Alarm 4 Delay Seconds	Write- alarm 4 delay to trip (seconds).	00	A4	Yes	Yes	Yes	Yes	0.0 to 600.0 seconds	0	r/w
84	40167	40166	0,1	Alarm 4 Direct Output	Read- direct alarm 4 output. 0: No alarm trip. 1: Alarm tripped.	00	A6	Yes	Yes	Yes	Yes	0: No alarm trip. 1: Alarm tripped.		ro
85	40169	40168	0,1	Alarm 4 Latched Output	Read- latched alarm 4 output. 0: Alarm not latched. 1: Alarm latched, write zero to clear latch.	00	A8	Yes	Yes	Yes	Yes	0: No alarm trip. 1: Alarm tripped.		ro
86	40171	40170	Index	Alarm 5 Input Parameter	Write- alarm 5 input parameter.	00	AA	Yes	Yes	Yes	Yes	0 to 255. Check with Input parameter table.	0	r/w
87	40173	40172	Value	Alarm 5 Trip Level	Write- alarm 5 parameter trip level.	00	AC	Yes	Yes	Yes	Yes	Any value in the selected parameters range.	0	r/w
88	40175	40174	Value	Alarm 5 Release Level	Write- alarm 5 parameter release level.	00	AE	Yes	Yes	Yes	Yes	Any value in the selected parameters range.	0	r/w
89	40177	40176	Seconds	Alarm 5 Delay Seconds	Write- alarm 5 delay to trip (seconds).	00	B0	Yes	Yes	Yes	Yes	0.0 to 600.0 seconds	0	r/w
90	40179	40178	0,1	Alarm 5 Direct Output	Read- direct alarm 5 output. 0: No alarm trip. 1: Alarm tripped.	00	B2	Yes	Yes	Yes	Yes	0: No alarm trip. 1: Alarm tripped.		ro
91	40181	40180	0,1	Alarm 5 Latched Output	Read- latched alarm 5 output. 0: Alarm not latched. 1: Alarm latched, write zero to clear latch.	00	B4	Yes	Yes	Yes	Yes	0: No alarm trip. 1: Alarm tripped.		ro
92	40183	40182	Index	Alarm 6 Input Parameter	Write- alarm 6 input parameter.	00	B6	Yes	Yes	Yes	Yes	0 to 255. Check with Input parameter table.	0	r/w
93	40185	40184	Value	Alarm 6 Trip Level	Write- alarm 6 parameter trip level.	00	B8	Yes	Yes	Yes	Yes	Any value in the selected parameters range.	0	r/w
94	40187	40186	Value	Alarm 6 Release Level	Write- alarm 6 parameter release level.	00	BA	Yes	Yes	Yes	Yes	Any value in the selected parameters range.	0	r/w
95	40189	40188	Seconds	Alarm 6 Delay Seconds	Write- alarm 6 delay to trip (seconds).	00	BC	Yes	Yes	Yes	Yes	0.0 to 600.0 seconds	0	r/w
96	40191	40190	0,1	Alarm 6 Direct Output	Read- direct alarm 6 output. 0: No alarm trip. 1: Alarm tripped.	00	BE	Yes	Yes	Yes	Yes	0: No alarm trip. 1: Alarm tripped.		ro
97	40193	40192	0,1	Alarm 6 Latched Output	Read- latched alarm 6 output. 0: Alarm not latched. 1: Alarm latched, write 0.0 to clear latch.	00	C0	Yes	Yes	Yes	Yes	0: No alarm trip. 1: Alarm tripped.		ro
98	40195	40194	0	Clear Alarm Latches	Read/Write- Write 0.0 to clear all alarm latches. Read zero.	00	C2	Yes	Yes	Yes	Yes	Write zero to all clear alarm latches. Read zero.	0	r/w
99	40197	40196		Alarm Release Delay	Write- Current Alarm Release Delay, 0 to 255 x 10ms, default 10 (100ms).	00	C4							
101	40201	40200	Index	Waveform Capture	Read/Write - Start/Stop capture. Write 1-1024 Delay start capture. 0: End capture. Read Capture Status. 1: Data captured. 0: Stand-by. Read captured data starting from parameter 1000.	00	C8	Yes	Yes	Yes	Yes	Read Capture Status. 1: Data captured. See Input Parameter Table. 0: Ready for Trigger. Write Capture Control. 1-1024: Trigger Capture. 0: Make Ready for Trigger If status is 'Ready for Trigger', trigger next capture by writing the number of samples to be captured after the trigger. For example, writing 500 will capture 500 samples after the trigger and 1024 - 500 = 524 samples before the trigger. Write zero to clear captured data and to return to Ready for Trigger.	0	r/w
102	40203	40202	Index	Waveform Capture Event	Read- capture event. 0: None. 1: Manual trigger. 2: Voltage sag event. 3: Voltage swell event.	00	CA	Yes	Yes	Yes	Yes	Read Waveform Capture Event. 0: None. 1: Manual trigger event via Modbus. 11: Voltage Sag trigger event. 12: Voltage Swell trigger event. 21 to 26: Alarm 1 to 6 trigger event. Write any value to Make Ready for Trigger.	0	ro
103	40205	40204	Count	Sag Waveform Capture	Start/Stop sag capture. Write 1-1024: Delay start capture. 0: Capture disabled.	00	CC	Yes	Yes	Yes	Yes	0: Capture disabled. 1 to 1024: Number of samples to capture after the trigger event.	0	r/w
104	40207	40206	Count	Swell Waveform Capture	Start/Stop swell capture. Write 1-1024: Delay start capture. 0: Capture disabled.	00	CE	Yes	Yes	Yes	Yes	0: Capture disabled. 1 to 1024: Number of samples to capture after the trigger event.	0	r/w
105	40209	40208				00	D0							
106	40211	40210				00	D2							
107	40213	40212				00	D4							
109	40217	40216	Index	Reset Logged Data	Write- code to reset data group. Code 0 for all of the following, except code 9. Code 1 for Energy. Code 2 for Demands Maximums. Code 3 for Demand Calculations and Maximums. Code 4 for Hours Run. Code 5 for Parameter Max/Mins. i.e. V1 to PF3. Code 6 for THD Max/Mins. Code 7 for Sag/Swell classification tables. Code 8 for Pulse Input counts. Code 9 for Soft Alarm Latches. Code 10 for Relay pulse counts. For code development only.	00	D8	Yes	Yes	Yes	Yes	0: For all of the following, except code 9. 1: Energy. 2: Demands maximums. 3: Demand calculations and maximums. 4: Hours run. 5: Parameter max/mins. i.e. V1 to PF3. 6: THD max/mins. 7: Sag/Swell classification tables. 8: Pulse input counts. 9: Soft alarm latches.		wo

110	40219	40218		Variation Counter	Read- count of readings processed.	00	DA												
111	40221	40220		Variation Parameter	Write the parameter number for parameter variation, and restart the variation calculation.	00	DC												
112	40223	40222		Parameter Variation Max	Read- the maximum parameter variation value.	00	DE												
113	40225	40224		Parameter Variation Mid	Read- the mid-range parameter variation value.	00	00												
114	40227	40226		Parameter Variation Min	Read the minimum parameter variation value.	00	00												
115	40229	40228		Parameter Variation	Read/Write- Read the percentage parameter variation. Write any value to restart the variation calculation.	00	00												
116	40231	40230	Text/Numerical	Product ID - Project Number	Read- the project number, 2187.	00	00	Yes	Yes	Yes	Yes	Yes	2225: CI Project 2225.	2225				ro	
117	40233	40232	Text/Numerical	Product ID - Product Number	Read- the product number, 101.2.	00	00	Yes	Yes	Yes	Yes	Yes	2100: Integra 2100.	2100				ro	
118	40235	40234	Numerical	Product ID - Software Version	Read- the firmware version number, or -version number for development.	00	EA	Yes	Yes	Yes	Yes	Yes	Negative numbers used during development.					ro	
119	40237	40236	Numerical	Product ID - Software Build	Read- the firmware build number, or -build number for development.	00	EC	Yes	Yes	Yes	Yes	Yes	Negative numbers used during development.					ro	
120	40239	40238	0	Product ID - PSC Issue	Read- the PSC issue number, 0 is normal.	00	EE	Yes	Yes	Yes	Yes	Yes	0: No PSC applied.	0				ro	
121	40241	40240	Numerical	Product ID - PSC Number	Read- the PSC number, 0 is normal.	00	F0	Yes	Yes	Yes	Yes	Yes	Last 6 digits of PSC number.	0				ro	
122	40243	40242	Volts	Calibration Volts V12	Write- actual calibration value, used by production only.	00	F2	No	No	No	No	No	Actual calibration volts V12.	0				r/w	
123	40245	40244	Volts	Calibration Volts V23	Write- actual calibration value, used by production only.	00	F4	No	No	No	No	No	Actual calibration volts V23.	0				r/w	
124	40247	40246	Volts	Calibration Volts V31	Write- actual calibration value, used by production only.	00	F6	No	No	No	No	No	Actual calibration volts V31.	0				r/w	
125	40249	40248	Volts	Calibration Volts V1	Write- actual calibration value, used by production only.	00	F8	Yes	Yes	No	No	No	Actual calibration volts V1.	0				r/w	
126	40251	40250	Volts	Calibration Volts V2	Write- actual calibration value, used by production only.	00	FA	Yes	Yes	No	No	No	Actual calibration volts V2.	0				r/w	
127	40253	40252	Volts	Calibration Volts V3	Write- actual calibration value, used by production only.	00	FC	Yes	Yes	No	No	No	Actual calibration volts V3.	0				r/w	
128	40255	40254	Amps	Calibration Amps A1	Write- actual calibration value, used by production only.	00	FE	Yes	No	No	No	No	Actual calibration amps A1.	0				r/w	
129	40257	40256	Amps	Calibration Amps A2	Write- actual calibration value, used by production only.	01	00	Yes	No	No	No	No	Actual calibration amps A2.	0				r/w	
130	40259	40258	Amps	Calibration Amps A3	Write- actual calibration value, used by production only.	01	02	Yes	No	No	No	No	Actual calibration amps A3.	0				r/w	
131	40261	40260	Amps	Calibration Amps AN	Write- actual calibration value, used by production only.	01	04												
132	40263	40262				01	06												
133	40265	40264	Volts	Secondary Volts Maximum	Read- the maximum secondary voltage that can be set.	01	08	Yes	Yes	Yes	Yes	Yes	Secondary volts maximum					ro	
134	40267	40266	Volts	Secondary Volts Minimum	Read- the minimum secondary voltage that can be set.	01	0A	Yes	Yes	Yes	Yes	Yes	Secondary volts minimum					ro	
135	40269	40268	Volts	Low Voltage Limit	Write- the lowest, non zero, value of VN or VLL as a proportion, see SYS_LOWVOLTLIMIT_F32DEF for value.	01	0C	Yes	Yes	Yes	Yes	Yes	0.0 – 0.05 PU	0.01 PU				r/w	
136	40271	40270	Amps	Low Amps Limit	Write- the lowest, non zero, value of line current as a proportion, see SYS_LOWAMPLIMIT_F32DEF for value.	01	0E	Yes	Yes	Yes	Yes	Yes	0.0 – 0.05 PU	0.008 PU				r/w	
137	40273	40272	THD	Low THD Parameter Limit	Write- the lowest, non zero, value of parameter PU for THD, see SYS_LOWLIMIT_THD_F32DEF for default value.	01	10	Yes	Yes	Yes	Yes	Yes	0.0 – 0.5 PU	0.05 PU				r/w	
138	40275	40274	Number	Parameter Smoothing Limit	Write- limit of parameter change for smoothing, see SYS_CAL_SMOOTHLIMIT_F32DEF for default value.	01	12	Yes	Yes	Yes	Yes	Yes	0.0 – 1.0	0.002				r/w	
139	40277	40276	Number	Parameter Smoothing Factor	Write- proportion of parameter change to use when smoothing, see SYS_CAL_SMOOTHFACTOR_F32DEF for default value.	01	14	Yes	Yes	Yes	Yes	Yes	0.0 – 1.0	0.002				r/w	
140	40279	40278	Number	THD Smoothing Limit	Write- limit of THD change for smoothing, see SYS_THD_SMOOTHLIMIT_F32DEF for default value.	01	16	Yes	Yes	Yes	Yes	Yes	0.0 – 1.0	0.005				r/w	
141	40281	40280	Number	THD Smoothing Factor	Read/Write - Write proportion of THD change to use when smoothing, see SYS_THD_SMOOTHFACTOR_F32DEF for default value.	01	18	Yes	Yes	Yes	Yes	Yes	0.0 – 1.0	0.02				r/w	
142	40283	40282	0,1	Instrument Status Summary	Read- the instrument status, zero = ok, 1 = error. See parameters 160 and 161.	01	1A	Yes	Yes	Yes	Yes	Yes	0: Instrument working normally, 1: Instrument error, no measured input parameters available.					ro	
143	40285	40284	VA	Low VA For Power Factor	Write- phase VA proportion required to include phase in power factor and phase angle calculations. See SYS_LOWVAFORPOWERFACTOR_F32DEF for value.	01	1C	Yes	Yes	Yes	Yes	Yes	0.0 – 0.05	0.03				r/w	
144	40287	40286	Number	Low Power Limit	Write- the lowest, non zero, value of Pn, VAn or VArn as a proportion, see SYS_LOWPOWERLIMIT_F32DEF for value.	01	1E	Yes	Yes	Yes	Yes	Yes	0.0 – 0.05	0.01				r/w	
145	40289	40288	10 to 65000	Calibration Offset Sample	Write- number of readings in offset calculation, default 32. Used by production only.	01	20	Yes	Yes	Yes	Yes	Yes	10 – 65000	32				r/w	
146	40291	40290	10 to 65000	Calibration Gain Sample	Write- number of readings in gain calculation, default 1024. Used by production only.	01	22	Yes	Yes	Yes	Yes	Yes	10 – 65000	1024				r/w	
147	40293	40292	10 to 65000	Calibration Phase Sample	Write- number of readings in phase calculation, default 4096. Used by production only.	01	24	Yes	Yes	Yes	Yes	Yes	10 – 65000	4096				r/w	
148	40295	40294				01	26												
149	40297	40296				01	28												
150	40299	40298	Volts	Secondary Voltage	Write- required secondary voltage, see SYS_SECONDARYLVOLTS_F32DEF, SYS_SECONDARYVLLVOLTS_F32DEF and SYS_SECLNVOLTS_1P3W_F32DEF for value.	01	2A	Yes	Yes	Yes	Yes	Yes	See max and min above.					r/w	
151	40301	40300				01	2C												
152	40303	40302	Volts	Nominal Voltage	Read- the voltage used during calibration. See SYS_NOMINALLVOLTS_F32DEF and SYS_NOMINALLVOLTS_F32DEF for value.	01	2E	Yes	Yes	Yes	Yes	Yes	The secondary voltage used during calibration.					ro	
154	40307	40306				01	32												
155	40309	40308		Status Group Range	Read- flash group status flags range. 0: Low order flags 1 to 15. 1: High order flags 16 to 31.	01	34												
156	40311	40310		Status Group 7	Read- Flash data read group 7 status flags.	01	36												
157	40313	40312		Status Group 8	Read- Flash data read group 8 status flags.	01	38												
158	40315	40314		Status Group 9	Read- Flash data read group 9 status flags.	01	3A												
159	40317	40316		Status Group 0	Read- Flash data read group 0 status flags.	01	3C												
160	40319	40318		Inst Status Flags Hi	Read the higher 16 instrument status flags. See table at the end of file ...Status.c for details.	01	3E												
161	40321	40320		Inst Status Flags Lo	Read the lower 16 instrument status flags. See table at the end of file ...Status.c for details.	01	40												
162	40323	40322		Status Group 1	Flash data read group 1 status flags.	01	42												
163	40325	40324		Status Group 2	Flash data read group 2 status flags.	01	44												
164	40327	40326		Status Group 3	Flash data read group 3 status flags.	01	46												
165	40329	40328		Status Group 4	Flash data read group 4 status flags.	01	48												
166	40331	40330		Status Group 5	Flash data read group 5 status flags.	01	4A												
167	40333	40332		Status Group 6	Flash data read group 6 status flags.	01	4C												

168	40335	40334	Values	Flash Memory Read Status	Read - Flash data read checksum status flags.	01	4E	Yes	Yes	Yes	Yes	Failures are non-zero. Read zero for last read Ok		ro
169	40337	40336	Values	EEPROM Write Activity	Read - EEPROM logging status.	01	50	Yes	Yes	Yes	Yes			ro
170	40339	40338	Values	Cal Phase Offset P1	Write- phase error in calibration source (degrees), used by production only.	01	52	Yes	Yes	Yes	Yes	Fault codes		ro
171	40341	40340	Values	Cal Phase Offset P2	Write- phase error in calibration source (degrees), used by production only.	01	54	Yes	Yes	Yes	Yes	Fault codes		ro
172	40343	40342	Values	Cal Phase Offset P3	Write- phase error in calibration source (degrees), used by production only.	01	56	Yes	Yes	Yes	Yes	Fault codes		ro
173	40345	40344	Values	EEPROM Read Status	EEPROM data checksum passes out of 64.	01	58	Yes	Yes	Yes	Yes	Failures are non-zero. Read zero for last read Ok		ro
174	40347	40346	Values	EEPROM Write Status	EEPROM write operations for last data log entry.	01	5A	Yes	Yes	Yes	Yes	Failures are non-zero. Read zero for last read Ok		ro
175	40349	40348	Volts	Sag/Swell Sliding Ref Voltage	Read - Sliding Voltage Reference used for Sags and Swells.	01	5C	Yes	Yes	Yes	Yes	Read current ref voltage (VSR)		ro
176	40351	40350	Volts	Sag/Swell Fixed Ref Voltage	Read- Fixed Voltage Reference used for Sags and Swells.	01	5E	Yes	Yes	Yes	Yes	Read/Write Fixed Reference Voltage. 1 and above: Use as Fixed Reference Voltage. 0: Use Sliding Reference Voltage.	0	r/w
177	40353	40352	0,1	Sag/Swell Ref Initialising	Read - Initialising Sags and Swells reference.	01	60	Yes	Yes	Yes	Yes	Read reference initialising flag. 0: Ready. 1: Initialising. Sliding reference takes 5 minutes.		ro
178	40355	40354				01	62							
179	40357	40356	0,1	Broadcast Enable	Read/Write - Read Modbus broadcast enable flag. Write: 0 to disable or 1 to enable.	01	64	Yes	Yes	Yes	Yes	Read/Write Broadcast message enable flag. 0: Disabled. 1: Enabled.	0	r/w
180	40359	40358	Number	Broadcast Status	Read/Write- Read status from last Modbus broadcast message. Write any value to clear.	01	66	Yes	Yes	Yes	Yes	Write any value to clear.	0	r/w
181	40361	40360	Number	Broadcast Count	Read/Write- Read the count of Modbus broadcast messages. Write any value to clear.	01	68	Yes	Yes	Yes	Yes	Write any value to clear.	0	r/w
191	40381	40380	Number of samples.	Alarm Capture Count 1	Read/Write- alarm 1 capture count. Write 1-1024: Delay start capture. 0: Capture disabled.	01	7C	Yes	Yes	Yes	Yes	0: Capture disabled. 1 to 1024: Number of samples to capture after the trigger event.	0	r/w
192	40383	40382	Number of samples.	Alarm Capture Count 2	Read/Write- alarm 2 capture count. Write 1-1024: Delay start capture. 0: Capture disabled.	01	7E	Yes	Yes	Yes	Yes	0: Capture disabled. 1 to 1024: Number of samples to capture after the trigger event.	0	r/w
193	40385	40384	Number of samples.	Alarm Capture Count 3	Read/Write- alarm 3 capture count. Write 1-1024: Delay start capture. 0: Capture disabled.	01	80	Yes	Yes	Yes	Yes	0: Capture disabled. 1 to 1024: Number of samples to capture after the trigger event.	0	r/w
194	40387	40386	Number of samples.	Alarm Capture Count 4	Read/Write- alarm 4 capture count. Write 1-1024: Delay start capture. 0: Capture disabled.	01	82	Yes	Yes	Yes	Yes	0: Capture disabled. 1 to 1024: Number of samples to capture after the trigger event.	0	r/w
195	40389	40388	Number of samples.	Alarm Capture Count 5	Read/Write- alarm 5 capture count. Write 1-1024: Delay start capture. 0: Capture disabled.	01	84	Yes	Yes	Yes	Yes	0: Capture disabled. 1 to 1024: Number of samples to capture after the trigger event.	0	r/w
196	40391	40390	Number of samples.	Alarm Capture Count 6	Read/Write- alarm 6 capture count. Write 1-1024: Delay start capture. 0: Capture disabled.	01	86	Yes	Yes	Yes	Yes	0: Capture disabled. 1 to 1024: Number of samples to capture after the trigger event.	0	r/w
200	40399	40398	°C	Under Temperature	Read/Write - Under temperature.	01	8E	Yes	Yes	Yes	Yes	Measurement Range -55 to 150 °C		r/w
201	40401	40400	°C	Over Temperature	Read/Write - Over temperature.	01	90	Yes	Yes	Yes	Yes	Over temperature.	64 °C	r/w
202	40403	40402	°C	Critical Temperature	Read/Write - Critical temperature.	01	92	Yes	Yes	Yes	Yes	Critical temperature.	147 °C	r/w
203	40405	40404	°C	Temperature Hysteresis	Read/Write - Temperature hysteresis.	01	94	Yes	Yes	Yes	Yes	Temperature hysteresis.	5 °C	r/w
204	40407	40406	°C	Current Temperature	Read/Write - Current temperature.	01	96	Yes	Yes	Yes	Yes	Measurement Range -55 to 150 °C		r/w
205	40409	40408	°C	Temperature Device ID	Read/Write - Temperature device ID.	01	98	Yes	Yes	Yes	Yes	Temperature device ID.	0xCX	r/w
206	40411	40410	°C	Temperature Device Config	Read/Write - Temperature device configuration.	01	9A	Yes	Yes	Yes	Yes	Temperature device configuration.	0x00	r/w
207	40413	40412	°C	Temperature Device Status	Read/Write - Temperature device status.	01	9C	Yes	Yes	Yes	Yes	Temperature device status.	0x80	r/w
208	40415	40414				01	9E							
209	40417	40416				01	A0							
210	40419	40418	Seconds	Real Time Clock Register 0	Read/Write - Tenth and Hundredths of Seconds	01	A2	Yes	Yes	Yes	Yes	tenths and Hundredths of a Second		r/w
211	40421	40420	Seconds	Real Time Clock Seconds	Read/Write - Seconds.	01	A4	Yes	Yes	Yes	Yes	Seconds.		r/w
212	40423	40422	Minutes	Real Time Clock Minutes	Read/Write - Minutes.	01	A6	Yes	Yes	Yes	Yes	Minutes.		r/w
213	40425	40424	Hours	Real Time Clock Hours	Read/Write - Hours.	01	A8	Yes	Yes	Yes	Yes	Hours.		r/w
214	40427	40426	Days	Real Time Clock Day	Read/Write - Day.	01	AA	Yes	Yes	Yes	Yes	Days.		r/w
215	40429	40428	Date	Real Time Clock Date	Read/Write - Date.	01	AC	Yes	Yes	Yes	Yes	Date.		r/w
216	40431	40430	Month	Real Time Clock Month	Read/Write - Month.	01	AE	Yes	Yes	Yes	Yes	Month.		r/w
217	40433	40432	Year	Real Time Clock Year	Read/Write - Year.	01	B0	Yes	Yes	Yes	Yes	Year.		r/w
218	40435	40434		Real Time Clock Register 8	Read/Write - Control register	01	B2	Yes	Yes	Yes	Yes	Control register		r/w
219	40437	40436		Real Time Clock Register 9	Read/Write - Calibration	01	B4	Yes	Yes	Yes	Yes	Calibration		r/w
220	40439	40438	Year	Real Time Clock Leap Year	Read/Write - Leap Year.	01	B6	Yes	Yes	Yes	Yes	Leap Year.		r/w
235	40469	40468	Numerical	Long Node Add Offset	Read/Write Node Address Offset.	01	D4	Yes	Yes	Yes	Yes	0: Minimum. 255: Maximum. 250: Default.		r/w
236	40471	40470	Numerical	Long Node Add Float	Read Node Address as float.	01	D6	Yes	Yes	Yes	Yes	0 to 59999.		ro
237	40473	40472	Numerical	Long Node Add Long	Read Node Address as long.	01	D8	Yes	Yes	Yes	Yes	0 to 59999.		ro
238	40475	40474												

250	40499	40498	Data bits 16 to 31	Instrument Status Flags High	Read - Instrument status flags. 16 to 31.	01	F2	Yes	Yes	Yes	Yes	Instrument Level Fault Code		ro
251	40501	40500	Data bits 0 to 15	Instrument Status Flags Low	Read - Instrument status flags. 0 to 15.	01	F4	Yes	Yes	Yes	Yes	Instrument Level Fault Code		ro
252	40503	40502	Data bits 16 to 31	Status Group 0 Hi	Read - Calibration status flags. 16 to 31.	01	F6	Yes	Yes	Yes	Yes	Fault Code		ro
253	40505	40504	Data bits 0 to 15	Status Group 0 Lo	Read - Calibration status flags. 0 to 15.	01	F8	Yes	Yes	Yes	Yes	Fault Code		ro
254	40507	40506	Data bits 16 to 31	Status Group 1 Hi	Read - Group 1 System status flags. 16 to 31.	01	FA	Yes	Yes	Yes	Yes	Fault Code		ro
255	40509	40508	Data bits 0 to 15	Status Group 1 Lo	Read - Group 1 System status flags. 0 to 15.	01	FC	Yes	Yes	Yes	Yes	Fault Code		ro
256	40511	40510	Data bits 16 to 31	Status Group 2 Hi	Read - Group 2 System status flags. 16 to 31.	01	FE	Yes	Yes	Yes	Yes	Fault Code		ro
257	40513	40512	Data bits 0 to 15	Status Group 2 Lo	Read - Group 2 System status flags. 0 to 15.	02	00	Yes	Yes	Yes	Yes	Fault Code		ro
258	40515	40514	Data bits 16 to 31	Status Group 3 Hi	Read - Group 3 System status flags. 16 to 31.	02	02	Yes	Yes	Yes	Yes	Fault Code		ro
259	40517	40516	Data bits 0 to 15	Status Group 3 Lo	Read - Group 3 System status flags. 0 to 15.	02	04	Yes	Yes	Yes	Yes	Fault Code		ro
260	40519	40518	Data bits 16 to 31	Status Group 4 Hi	Read - Group 4 System status flags. 16 to 31.	02	06	Yes	Yes	Yes	Yes	Fault Code		ro
261	40521	40520	Data bits 0 to 15	Status Group 4 Lo	Read - Group 4 System status flags. 0 to 15.	02	08	Yes	Yes	Yes	Yes	Fault Code		ro
262	40523	40522	Data bits 16 to 31	Status Group 5 Hi	Read - Group 5 System status flags. 16 to 31.	02	0A	Yes	Yes	Yes	Yes	Fault Code		ro
263	40525	40524	Data bits 0 to 15	Status Group 5 Lo	Read - Group 5 System status flags. 0 to 15.	02	0C	Yes	Yes	Yes	Yes	Fault Code		ro
264	40527	40526	Data bits 16 to 31	Status Group 6 Hi	Read - Group 6 System status flags. 16 to 31.	02	0E	Yes	Yes	Yes	Yes	Fault Code		ro
265	40529	40528	Data bits 0 to 15	Status Group 6 Lo	Read - Group 6 System status flags. 0 to 15.	02	10	Yes	Yes	Yes	Yes	Fault Code		ro
266	40531	40530	Data bits 16 to 31	Status Group 7 Hi	Read - Group 7 System status flags. 16 to 31.	02	12	Yes	Yes	Yes	Yes	Fault Code		ro
267	40533	40532	Data bits 0 to 15	Status Group 7 Lo	Read - Group 7 System status flags. 0 to 15.	02	14	Yes	Yes	Yes	Yes	Fault Code		ro
268	40535	40534	Data bits 16 to 31	Status Group 8 Hi	Read - Group 8 System status flags. 16 to 31.	02	16	Yes	Yes	Yes	Yes	Fault Code		ro
269	40537	40536	Data bits 0 to 15	Status Group 8 Lo	Read - Group 8 System status flags. 0 to 15.	02	18	Yes	Yes	Yes	Yes	Fault Code		ro
270	40539	40538	Data bits 16 to 31	Status Group 9 Hi	Read - Group 9 System status flags. 16 to 31.	02	1A	Yes	Yes	Yes	Yes	Fault Code		ro
271	40541	40540	Data bits 0 to 15	Status Group 9 Lo	Read - Group 9 System status flags. 0 to 15.	02	1C	Yes	Yes	Yes	Yes	Fault Code		ro
272	40543	40542				02	1E							
273	40545	40544				02	20							
274	40547	40546				02	22							
275	40549	40548	Index	LCD User Screen Parameter 1	Read/Write - NVM data for display user screen 1.	02	24	Yes	Yes	Yes	Yes	LCD user screen parameter 1.		r/w
276	40551	40550	Index	LCD User Screen Parameter 2	Read/Write - NVM data for display user screen 2.	02	26	Yes	Yes	Yes	Yes	LCD user screen parameter 2.		r/w
277	40553	40552	Index	LCD User Screen Parameter 3	Read/Write - NVM data for display user screen 3.	02	28	Yes	Yes	Yes	Yes	LCD user screen parameter 3.		r/w
278	40555	40554	Index	LCD User Screen Parameter 4	Read/Write - NVM data for display user screen 4.	02	2A	Yes	Yes	Yes	Yes	LCD user screen parameter 4.		r/w
279	40557	40556	Index	LCD User Screen Parameter 5	Read/Write - NVM data for display user screen 5.	02	2C	Yes	Yes	Yes	Yes	LCD user screen parameter 5.		r/w
299	40597	40596		Last User PW Option	Last parameter where user password is an option. Parameters between this and 999 will require the user password to write.	02	54							
304	40607	40606		Return Stack Check	Count of unused stack bytes.	02	5E							
305	40609	40608		Good Flash Writes	Count of good writes to Flash memory.	02	60							
310	40619	40618		AOC Type Code	Analogue hardware type code.	02	6A							
311	40621	40620		AOC Scale Sum	Scale summary flags. 0: mA and 1: Volts.	02	6C							
312	40623	40622		AOC Enable Sum	Enable summary flags.	02	6E							
313	40625	40624		Serial No 1	Serial number 1 from analogue module.	02	70							
314	40627	40626		Serial No 2	Serial number 2 from analogue module.	02	72							
315	40629	40628		AOC Reserved A	Analogue common reserved location A.	02	74							
316	40631	40630		AOC Reserved B	Analogue common reserved location B.	02	76							
317	40633	40632		AOC Reserved C	Analogue common reserved location C.	02	78							
318	40635	40634		AO1 Analogue Range	Channel 1 analogue range code.	02	7A							
319	40637	40636		AO1 Output Enable	Channel 1 analogue output enable flag.	02	7C							
320	40639	40638		AO1 Output Param No	Channel 1 analogue parameter number.	02	7E							
321	40641	40640		AO1 Dual Slope Flag	Channel 1 analogue dual slope flag.	02	80							
322	40643	40642		AO1 Low Limit Ana	Channel 1 lower analogue limit.	02	82							
323	40645	40644		AO1 Mid Limit Ana	Channel 1 middle analogue limit.	02	84							
324	40647	40646		AO1 Upper Limit Ana	Channel 1 upper analogue limit.	02	86							
325	40649	40648		AO1 Lower Limit Reg	Channel 1 lower parameter limit.	02	88							
326	40651	40650		AO1 Mid Limit Reg	Channel 1 middle parameter limit.	02	8A							
327	40653	40652		AO1 Upper Limit Reg	Channel 1 upper parameter limit.	02	8C							
328	40655	40654		AO1 Gain Adjust	Channel 1 gain adjustment (M).	02	8E							
329	40657	40656		AO1 Offset Adjust	Channel 1 offset adjustment (C).	02	90							
330	40659	40658		AO1 Error Code	Channel 1 analogue error code.	02	92							
331	40661	40660		AO1 Lower Limit Dig	Channel 1 lower digital limit.	02	94							
332	40663	40662		AO1 Mid Limit Dig	Channel 1 middle digital limit.	02	96							
333	40665	40664		AO1 Upper Limit Dig	Channel 1 upper digital limit.	02	98							
334	40667	40666		AO1 Present Ana	Channel 1 current analogue value.	02	9A							
335	40669	40668		AO1 Register Val	Channel 1 current parameter value.	02	9C							
336	40671	40670		AO1 Cal Low Point	Channel 1 calibration low point.	02	9E							
337	40673	40672		AO1 Cal High Point	Channel 1 calibration high point.	02	A0							
338	40675	40674		AO1 Present Dig Val	Channel 1 current digital value.	02	A2							
339	40677	40676		AO1 Reserved 1	Channel 1 reserved location 1.	02	A4							
340	40679	40678		AO1 Reserved 2	Channel 1 reserved location 2.	02	A6							
341	40681	40680		AO1 Reserved 3	Channel 1 reserved location 3.	02	A8							
342	40683	40682		AO2 Analogue Range	Channel 2 analogue range code.	02	AA							
343	40685	40684		AO2 Output Enable	Channel 2 analogue output enable flag.	02	AC							
344	40687	40686		AO2 Output Param No	Channel 2 analogue parameter number.	02	AE							
345	40689	40688		AO2 Dual Slope Flag	Channel 2 analogue dual slope flag.	02	B0							
346	40691	40690		AO2 Low Limit Ana	Channel 2 lower analogue limit.	02	B2							
347	40693	40692		AO2 Mid Limit Ana	Channel 2 middle analogue limit.	02	B4							
348	40695	40694		AO2 Upper Limit Ana	Channel 2 upper analogue limit.	02	B6							

4556	49111	49110		Micro Phase Angle P1	Read Phase Angle 1 in Micro Degrees, for phase cal testing.	23	96											
4557	49113	49112		Micro Phase Angle P2	Read Phase Angle 2 in Micro Degrees, for phase cal testing.	23	98											
4558	49115	49114		Micro Phase Angle P3	Read Phase Angle 3 in Micro Degrees, for phase cal testing.	23	9A											
4559	49117	49116	Counts	D0 Actual Phase Delay	Read- the actual D0 phase delay applied.	23	9C	Yes	Yes	Yes	Yes	Phase calibration delay 0.						ro
4560	49119	49118	Counts	D1 Actual Phase Delay	Read- the actual D1 phase delay applied.	23	9E	Yes	Yes	Yes	Yes	Phase calibration delay 1.						ro
4561	49121	49120	Counts	D2 Actual Phase Delay	Read- the actual D2 phase delay applied.	23	A0	Yes	Yes	Yes	Yes	Phase calibration delay 2.						ro
4562	49123	49122	Counts	D3 Actual Phase Delay	Read- the actual D3 phase delay applied.	23	A2	Yes	Yes	Yes	Yes	Phase calibration delay 3.						ro
4563	49125	49124	Counts	D4 Actual Phase Delay	Read- the actual D4 phase delay applied.	23	A4	Yes	Yes	Yes	Yes	Phase calibration delay 4.						ro
4564	49127	49126	Counts	Phase Delay Total	Read- the total phase delay.	23	A6	Yes	Yes	Yes	Yes	Phase calibration delay 5.						ro
4565	49129	49128	Counts	Total Phase Delay 1	Read- the total phase delay 1.	23	A8	Yes	Yes	Yes	Yes	Phase correction count 1.						ro
4566	49131	49130	Counts	Total Phase Delay 2	Read- the total phase delay 2.	23	AA	Yes	Yes	Yes	Yes	Phase correction count 2.						ro
4567	49133	49132	Counts	Total Phase Delay 3	Read- the total phase delay 3.	23	AC	Yes	Yes	Yes	Yes	Phase correction count 3.						ro
4569	49137	49136	Index	Phase Cal Feedback	Read- an assesment of the best phase calibration strategy.	23	B0	Yes	Yes	Yes	Yes	100: Strategy = 0. 101: Strategy = 1. 102: Strategy = 2.						ro
4570	49139	49138	Counts	Phase Cal Errors	Read - a count of phase calibration errors.	23	B2	Yes	Yes	Yes	Yes	Phase calibration error count.						ro
4571	49141	49140	Counts	Low Sample Interval	Read- lowest sample interval calculated.	23	B4	Yes	Yes	Yes	Yes	Lowest phase cal delay.						ro
4572	49143	49142				23	B6											
4580	49159	49158		Phase Cal 50	Read/Write- Phase 1 calibration at 50Hz.	23	C6											
4581	49161	49160		Phase Cal 51	Read/Write- Phase 1 calibration at 50Hz.	23	C8											
4582	49163	49162		Phase Cal 52	Read/Write- Phase 1 calibration at 50Hz.	23	CA											
4583	49165	49164		Phase Cal 60	Read/Write- Phase 1 calibration at 60Hz.	23	CC											
4584	49167	49166		Phase Cal 61	Read/Write- Phase 1 calibration at 60Hz.	23	CE											
4585	49169	49168		Phase Cal 62	Read/Write- Phase 1 calibration at 60Hz.	23	D0											
4586	49171	49170		Phase Cal 50 Hz	Read/Write- Phase calibration 50Hz.	23	D2											
4587	49173	49172		Phase Cal 60 Hz	Read/Write- Phase calibration 60Hz.	23	D4											
4723	49445	49444	48MHz Counts	Smoothed Sample Period	Read - Smoothed Sample Period.	24	E4	Yes	Yes	Yes	Yes	Approximately 7500 at 50Hz.						ro
4747	49493	49492				25	14											
4748	49495	49494				25	16											
4749	49497	49496				25	18											
4900	49799	49798				26	46											
to	to	to				to	to											
9999	59997	59996				4E	1C											